



## **Introduction**

This article is the second in a multi part series that describes the operating theory and construction guide for the Orgone Amplifier circuit. In this article we examine component construction, operating theory, and purpose within the Orgone Amplifier circuit. We will build on this knowledge to describe the circuit in terms that a computer will understand, and then simulate the oscillator using common simulation tools. We examine the voltage source in detail to understand how the RF harvesting circuit can draw power from the EM spectrum. After we describe antenna theory, we look to future improvements to create a more effective device. We will look at electrical characteristics to chose parts based on the application and describe how to fabricate key components, and then offer techniques on testing and troubleshooting. We offer circuit analysis techniques and apply them to a new circuit design with greater input voltages. The third article in this series will explore the nature of orgone and causal secondary effects.

Disclaimer: This article is for research & information purposes only. Activities performed during the making of this article are hazardous, and should not be performed by any unqualified personnel. The information in this article shall not be mistaken as medical, legal, financial advice or otherwise. The author, publisher, or hosting provider are not responsible for actions taken by the reader.

# Table of Contents

Introduction.....	1
Electrical Circuit Basics.....	4
Component Theory & Construction.....	7
Resistor:.....	8
Potentiometer:.....	8
Capacitor:.....	10
Inductor:.....	11
Transformer:.....	11
Diode:.....	12
Transistor:.....	13
Circuit Theory & Simulation.....	14
Air to Electric Interface.....	21
Antenna Theory.....	21
Electric waves.....	24
Simple RF Circuit.....	26
Impedance Matching Circuitry.....	34
Voltage Multiplier.....	37
Part Selection and Manufacture.....	39
The Crystal Emitter.....	39
Smaller Specimens.....	40
Larger Specimens.....	40
Crystal Cuts & Orientation.....	41
Orienting a cut crystal.....	42
Soldering Contacts to a Crystal.....	42
The Transformer.....	43
Transformer polarity test:.....	48
Transistor and other components.....	50
Parts List:.....	52
OA-100 RF Harvesting circuit parts list + diagram.....	52
OA-1000 Powered amplifier parts list + diagram.....	53
Build Steps (active unit).....	54
Designing a New Circuit.....	60
Troubleshooting.....	62
Case 1:.....	63
Case 2:.....	63
Case 3:.....	63
Case 4:.....	63
Advantages of the Orgone Amplifier Circuit and Defense of the Novelty.....	64
Temperature and Pressure Resistance.....	64
Operator Defined Intensity and Frequency.....	64
Power to Weight Ratio.....	64
Operator Environmental Feedback.....	64
Ability to Scale.....	65

Improvements & Future Work.....	65
Extended Frequency Response.....	65
Directional Antennas.....	65
Solar Power.....	65
Greater Input Voltages.....	66
Increased Control.....	66
Grounding.....	66
Scalar Orgone Emission.....	66
Tensor Orgone Emission.....	66
Multi – Phase Crystal Stimulation.....	66
Vortex Generator.....	67
Radionics Input.....	67
Audio Input.....	67
Aura /Brainwave/Bio-metric sensing.....	67
Conclusion.....	67

## Electrical Circuit Basics

To understand the Orgone Amplifier circuit, we must first understand the very basics of electrical circuits. For those who have a grasp on the concept of electricity, this section can be skipped. We must first consider what is an electrical force at the atomic level. Atoms are the most basic form of matter, and are composed of three elemental particles, the proton, neutron and electron.[1] The proton and electron are equal but oppositely charged, while a neutron has the same mass as a proton, but does not have an electrical charge. The protons and neutrons will form the nucleus of an atom, a very dense center charged positively and denoted with the + symbol. The electrons will arrange themselves in discrete vibrational states, called valence bands, denoted by a ring around the nucleus. Electrical forces are therefore concerned with the interactions of the electron and nucleus of the atom. Notice there are equal number of electrons and protons in this helium atom, as the tendency of atoms is to become charge neutral. To maintain charge neutrality an atom is composed of equal number of positive and negative charges. Due to being located within the nucleus, the positive charges are fixed in place, while the negative electrons are free to move around the nucleus or in some cases from atom to atom.

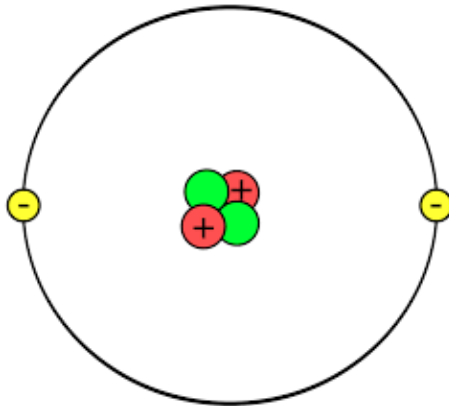

A purified metal is actually a crystal, a structure composed of tightly bound atoms with the electrons very free to move.

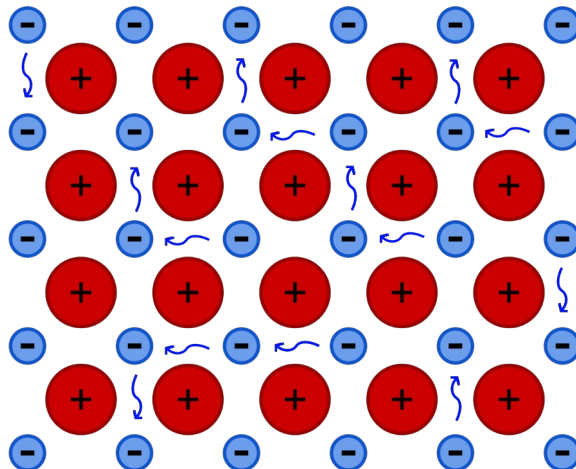

The free movement of electrons within a metal makes the material a good “conductor” of electric charge. Because electrons can move so freely, electron currents can flow within metal, allowing the transport of energy in the form of electrical charge. In other materials, if the nucleus of the atom has a



strong affinity to hold on to electrons, the material does not allow free movement, and is said to be an “insulator.”

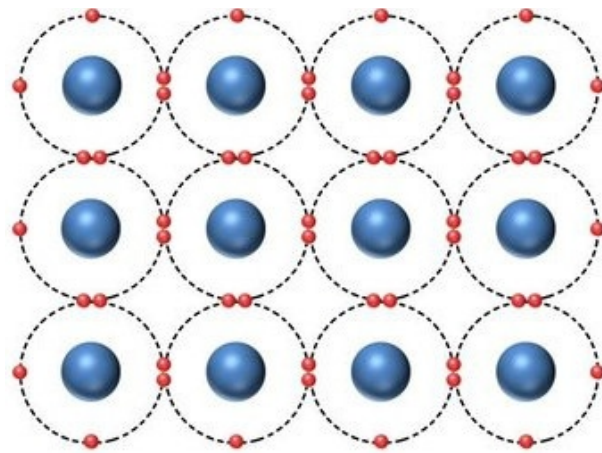

**Insulator**

A wire is a device with a metal core and an insulating exterior. By producing a metal/insulator structure in this manner, the flow of electrons is directed along the length of the wire.

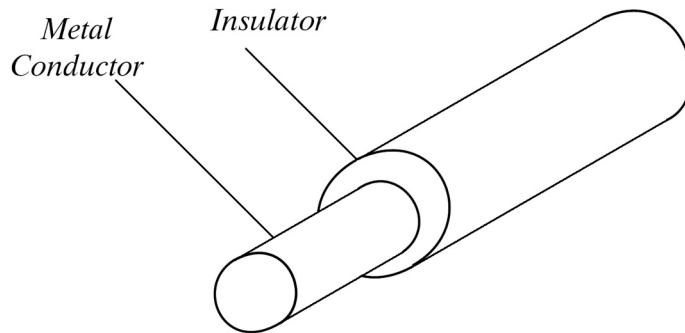

A wire is the simplest electrical device, and is used to bridge connections from one component to another. An ideal wire will allow electrical current to flow unimpeded from one point to another. In practice, this is not always true, but works well enough to be correct in most situations. When two or

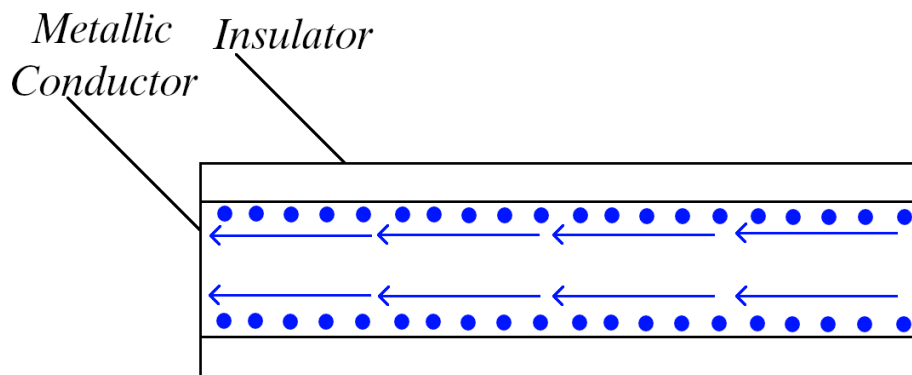

more wires are connected together, they form a “node” which allows the free movement of electrical current between any of the wires connected.

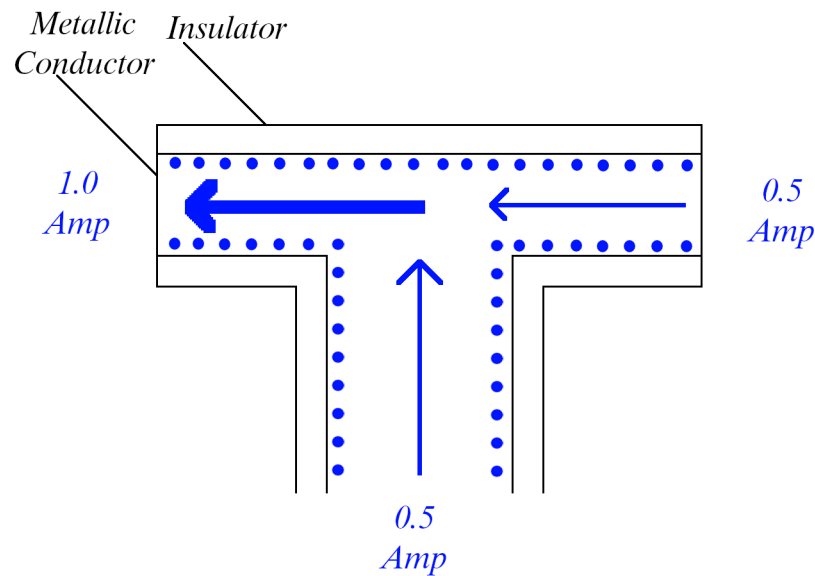

A node has two interesting properties, the first states that all currents must be equal. If there is (0.5Amperes) + (0.5 Amperes) of current entering the node, there must be 1 amperes of electrical current exiting the node. The second property of a node is the ability to share electrical voltage. Remember electrons are all the same charge, and like charges repel. Electrical pressure is caused when electrons are forced together, and **voltage** is the **difference** of electrical pressure **between two nodes**. [2]

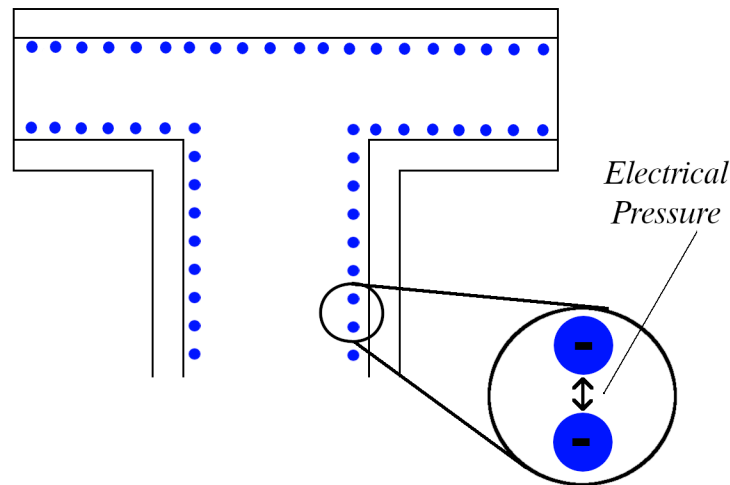

Every conductor connected to the node will share the same electrical pressure. Since like charges repel, it follows that an electrical pressure will distribute itself over an entire conductor until it runs up against an insulating medium. Even touching two metals together will create an electrical path between the two conductors, it is important that all points of a node are insulated from other conductors. This concept will be important when building the circuit in later sections of this document.

## Component Theory & Construction

The Orgone Amplifier is fairly simple in its operating theory, but the devices that it is built upon have taken the cumulative effort of humanity to refine. The Orgone Amplifier is built upon a mountain of knowledge and effort expended by many great scientists. Without the refinement of metals, the discovery of magnetism, the invention of the battery, the work of Maxwell, Tesla, Einstein, Curie, Schrodinger, Feynman and the many thousands of scientists studying semiconductor physics, we would not have many of the technologies that we have today, and the same goes for the Orgone Amplifier.

We will attempt to explain enough of the theory to understand the operation of this device, any mechanism or theory left unexplained here can be found in a physics, electronics, or semiconductor textbook. This article will be longer and slightly more dense than the first, as it is intended to describe operating theory and construction in great detail. If the reader does not intend to build an amplifier circuit, portions of this article can be skipped.

We will remind the reader of the example orgone amplifier, pictured below:

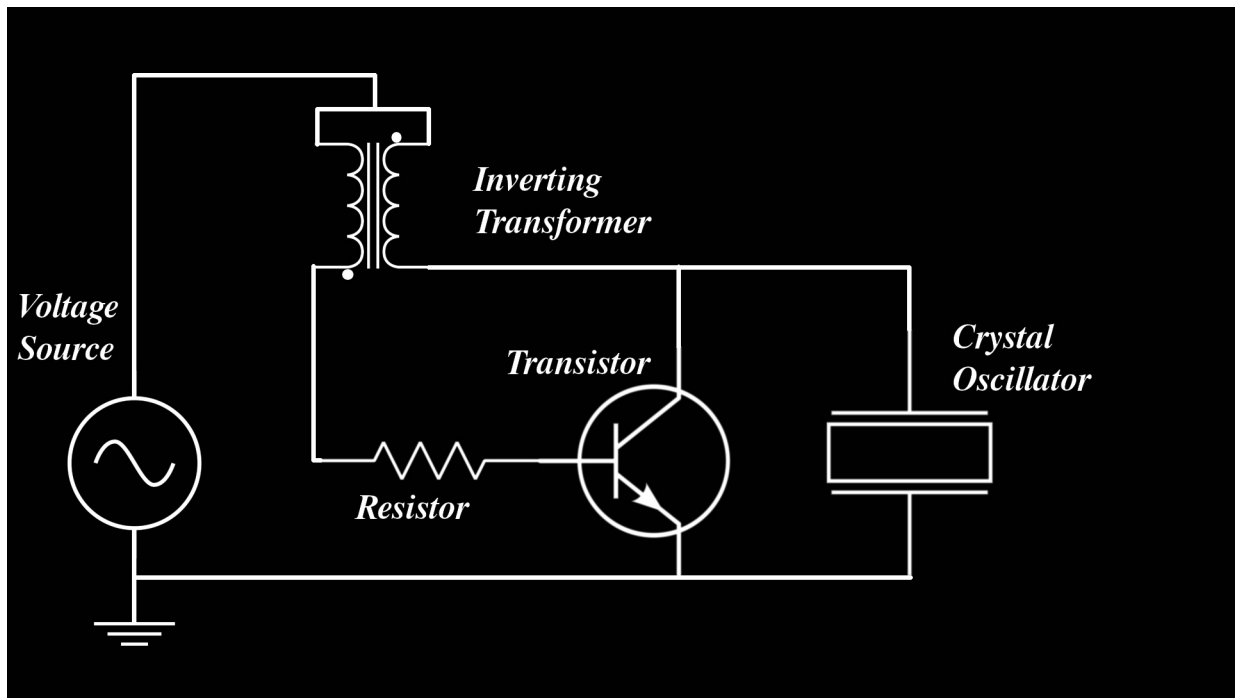

Components used in the OA circuit are described in order of least complex to most complex.

**Resistor:**

**The resistor** is a device that **impedes the flow of charge** according to ohms law. If a certain electrical pressure is applied to the device, it will only let through a certain flow of charge. The common analogy that is used to describe a resistor is a kink in a tube. Observe the below diagram of a hose with a bend:

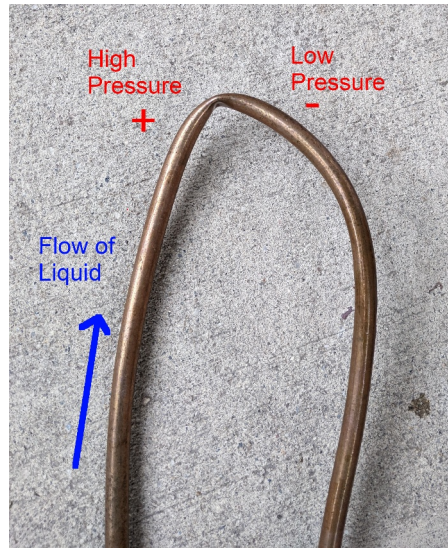

When liquid flows through the above pipe, the bend in the tube constricts the flow, and creates a high pressure zone before the bend, and a low pressure zone after the constriction. The electrical resistor is analogous to the constriction in the pipe, and resists the flow of electrical current through the device. We see the same high pressure and low pressure zones across the resistor, and this is called a voltage difference. Below is the electrical diagram of the resistor along with a diagram of the internal construction. We can see that internal to the resistor, the metal strip connecting the contacts is cut to constrict the available cross section for current to flow, an electrical analogy for a kink in a pipe.

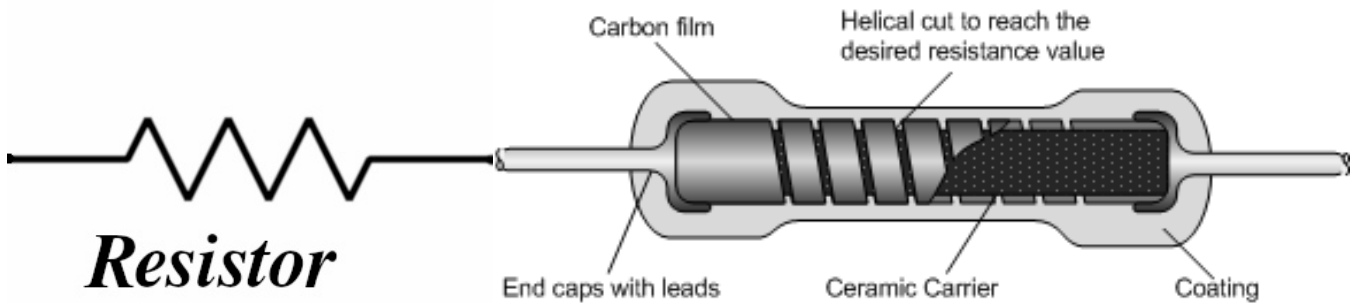

**Potentiometer:**

The value of resistance is chosen when the resistor is manufactured, but a device called a potentiometer or rheostat can be created to vary the resistances within a circuit. The knobs on the exterior of the Orgone Amplifier are potentiometers, and allow the user to control the operation of the device. A

potentiometer is often called a variable resistor, because it **allows the user to change the resistance in the circuit**, allowing the user to **affect the operation without replacing components**. A potentiometer has a rotary knob attached to a mechanical arm within the case of the device. Below are images in some common potentiometers used in the Orgone Amplifier circuit:



Below is an internal diagram of the potentiometer:

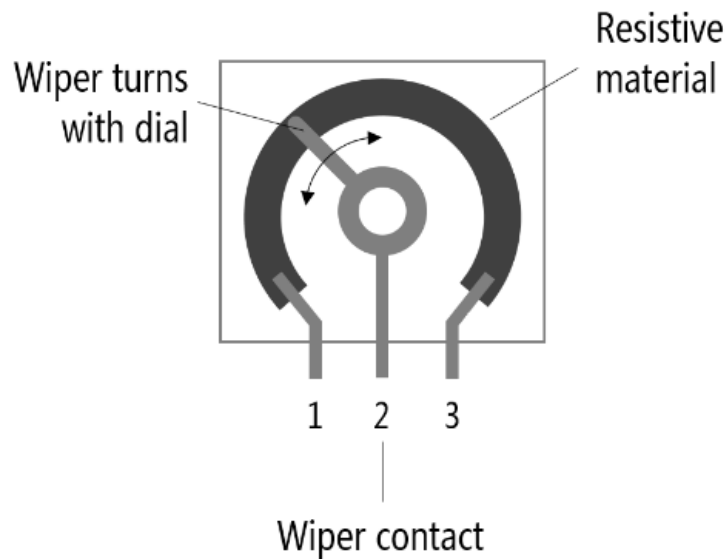

We can see from the diagram that the wiper makes contact with the resistive material and changes the resistance between pins 1 and 2, or pins 2 and 3. When the wiper moves clockwise, the resistance between pins 1 and 2 increases, while the resistance between pins 2 and 3 decreases. The opposite is true when the dial is turned counter clockwise.

## Capacitor:

A capacitor is a device that can be thought of as an electrical spring, and stores electrical pressure across its two terminals. It is constructed by placing alternating layers of conductor and insulator material, with every other conductor connected to one lead while the opposite is connected to the other. A visual is included below:

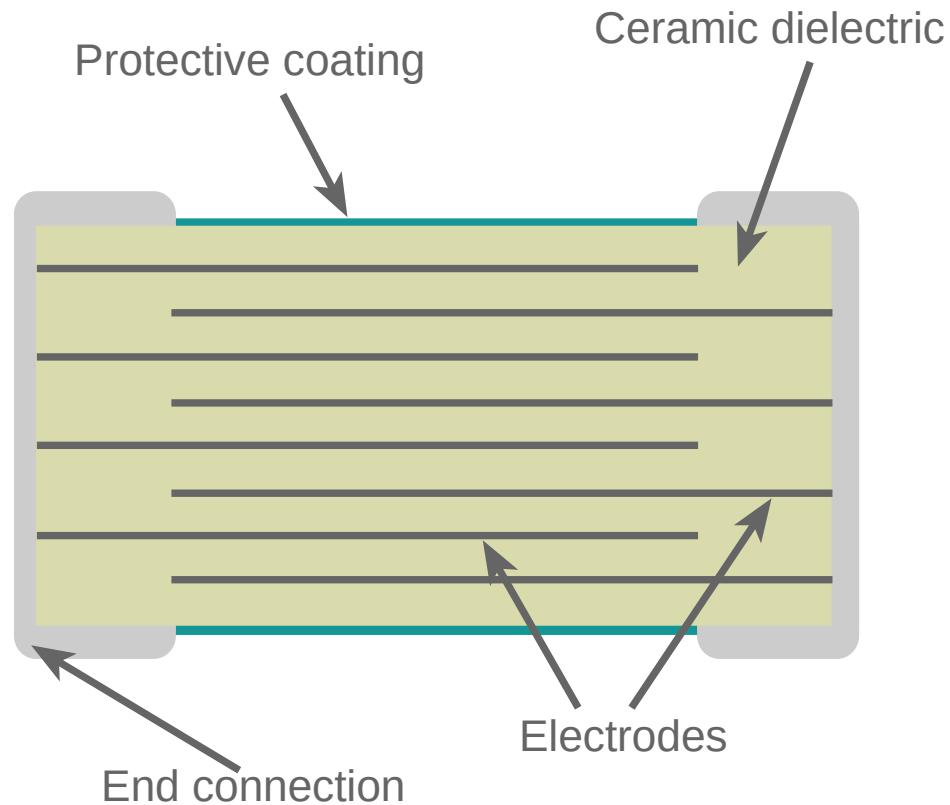

The overlapping area of the two conductors allows an electric field to build up a store of charge, in turn allowing electrical energy to be stored within this device. Capacitance is directly proportional to the area of the overlapping conductors, as a greater surface area allows a greater amount of charge to be stored per unit voltage. **A capacitor will store charge and give it back to the circuit with great ferocity.** Like compressing a spring, this device has the ability to store energy within the electric field and give it back to the circuit almost instantaneously.

### Inductor:

an inductor is similar to a capacitor, but instead of storing energy in an electric field, the inductor stores energy in the magnetic field. An effect of Lenz's law states that loops of wire create a magnetic field when current is flowing through the coil. By coiling the wire many times in a common direction, a greater magnetic field can be created through the coil. The greater the magnetic field, the more energy it takes to set up, so there is a high resistance to a change in current flow when voltage is first applied, but as the magnetic field is set up, the resistance goes down and current can pass through easily. **If voltage across the inductor is removed, the inductor will provide current until the energy in the magnetic field is exhausted.** A diagram of an inductor is included below:

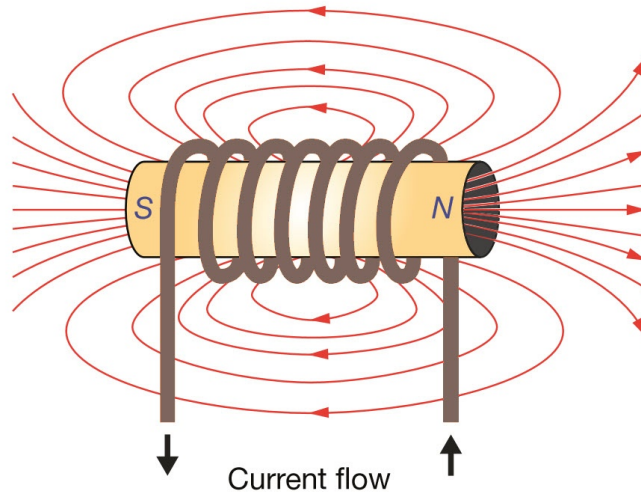

### Transformer:

A transformer builds on the idea of an inductor by allowing the changing magnetic field from one coil to induce a current into the wire of the next.

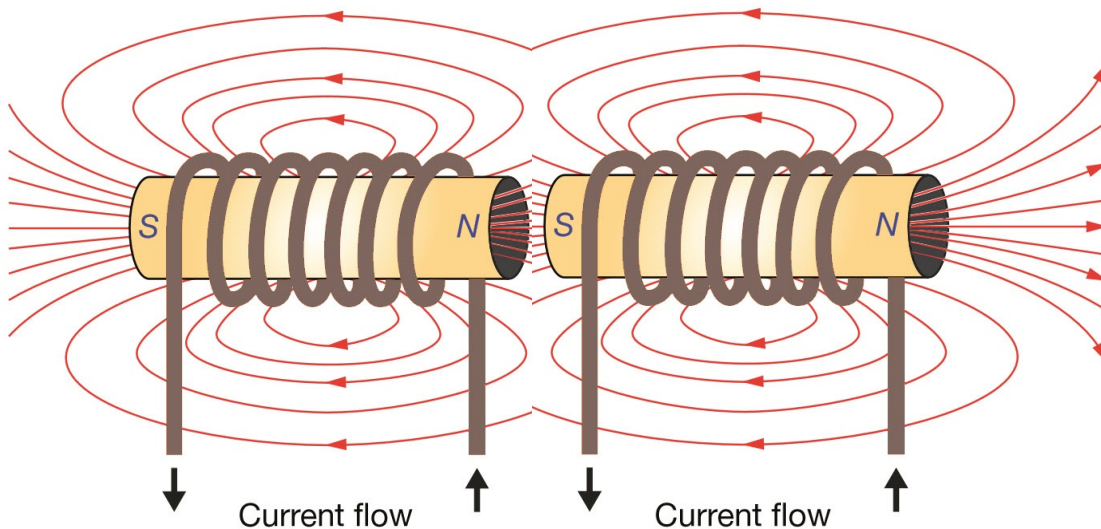

The electrical energy is transformed from an electric field to a magnetic field, and then back to an electric field in the second coil. The input coil is referred to as the “primary” and the output coil is



referred to as the “secondary.” If there is an equal number of loops around the magnet in the primary coil as the secondary coil, the electrical signal in the second coil is replicated 1:1. A crucial distinction about the transformer is that it is an alternating current device. If the electric current through the wire is not changing, there will be no currents induced in the secondary winding. The primary may still carry a DC current, but only alternating signals will be transferred to the secondary. This means that only quick frequencies or pulses will transfer through the magnetic field to the secondary coil. **If the secondary coil is wired in reverse the induced current is the opposite polarity.** We denote the polarity of the transformer with the dot at the top of the coil. If both of the dots are at the top, the output polarity will be the same as the input. If the dots are opposite, it communicates the secondary coil will output the inverse of the input signal.

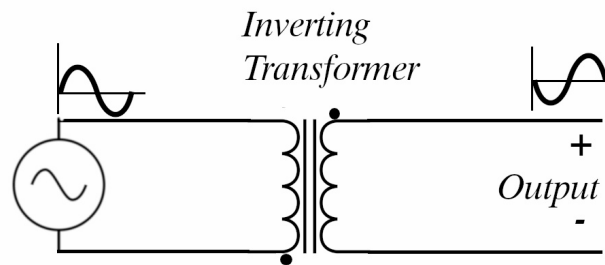

**Using the transformer** in the inverting configuration **we can apply positive feedback** to the transistor **and induce spontaneous oscillations** in the Orgone Amplifier circuit.

### **Diode:**

A diode is the simplest semiconductor device. A semiconductor is a device that is a conductor of electric current only part time and under certain conditions. If those conditions are not met, it acts like an insulator. By controlling the conditions that a semiconductor will allow current, a multitude of interesting devices can be made. To start with a simple explanation of a semiconductor, we start with the most base element, silicon. Silicon is a group 4 element, like carbon. It has 4 bonding sites and when ultra pure, can form a crystalline structure which looks similar to a metal. All computer chips are fabricated from this ultra pure silicon structure. The pure silicon crystal then has impurities selectively introduced to create interesting effects. The impurities are usually Boron a group III positively charged atom, and phosphorus a group V negatively charged atom. By selectively adding impurities or “doping,” certain areas of the micro device can be electrically charged positively or negatively. Positive

areas are called “p-type” semiconductor and negative areas are called “n-type” semiconductor. A diode is a structure with one half p-type and the other half n-type, as seen below:

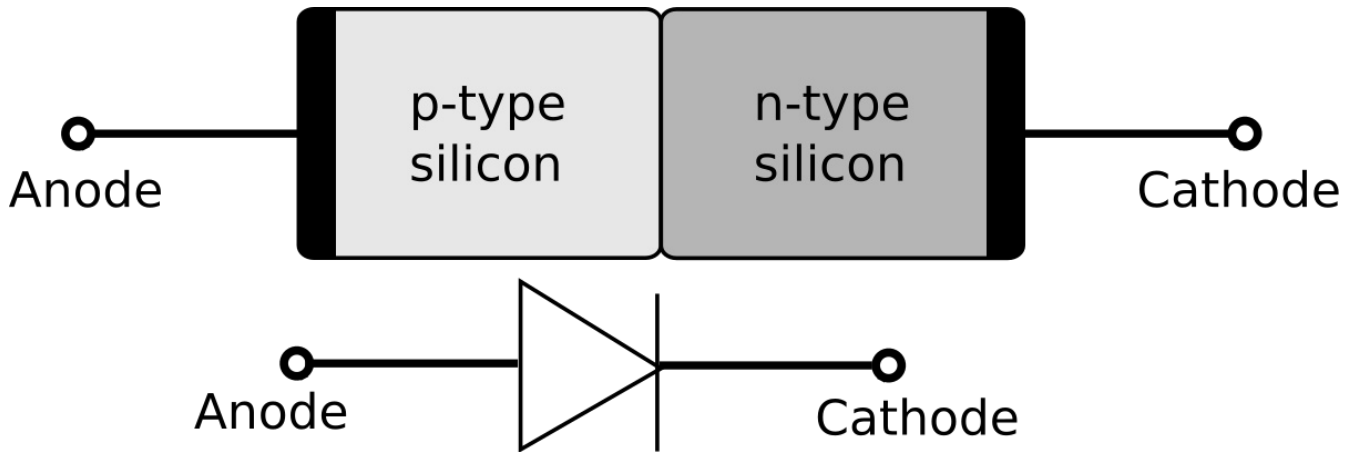

The interface between the P-type and N-type silicon is called a “p-n junction” and its **purpose is to let electrical energy pass only one way**. It is the **electronic equivalent of a check valve**, and will allow current to flow in one direction from Anode to Cathode, left to right. This effect will be important when building the air to electric interface.

**Transistor:**

A transistor has many modes and functions, but its operation can be simplified to be **an electrically operated switch**. The device has three terminals, labeled C,B and E which correspond to the Collector, Base and Emitter. Below is a bipolar junction NPN transistor, the type used in the Orgone Amplifier Circuit:

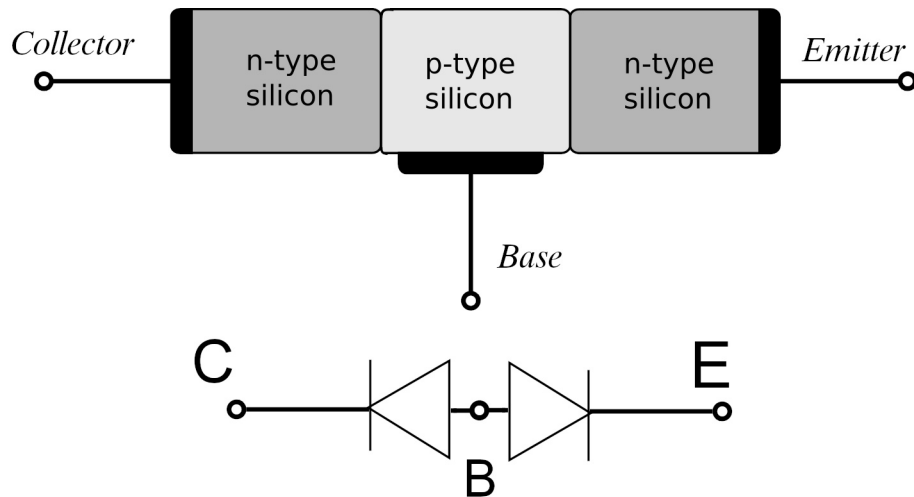

The right half looks very similar to the diode, and can be simplified to look like two diodes with a common anode internal to the device.

When the voltage between terminal B and E is zero, the device will let no current pass between terminal E and C.

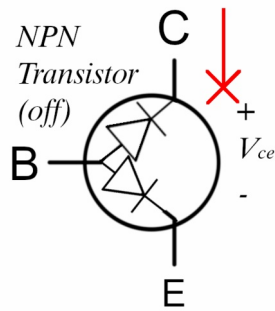

If the voltage between B and E is above some turn on voltage, usually 0.7 volts for silicon, the device will let current flow from terminal C to E.

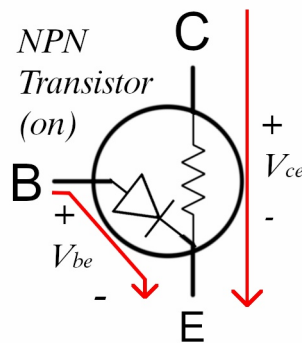

In this way the device acts both like a switch and an amplifier, with **two distinct states “off”** represented by two diodes that impede current, and **“on”** represented by a diode and resistor which allows current through the device. During the “on” state, the device will allow a large amount of current between terminals C and E. If too much current is sent through terminals C and E, the device will reject additional current and will enter “Saturation mode” as shown by the below graph.

This is a **massive simplification** of the inner workings of this device, but this simplified model **allows us to describe the influence** the bipolar junction transistor has on the Orgone Amplifier Circuit.

Having a glimpse into the mechanics of each component operation, we put them together to create the oscillator circuit of the Orgone Amplifier.

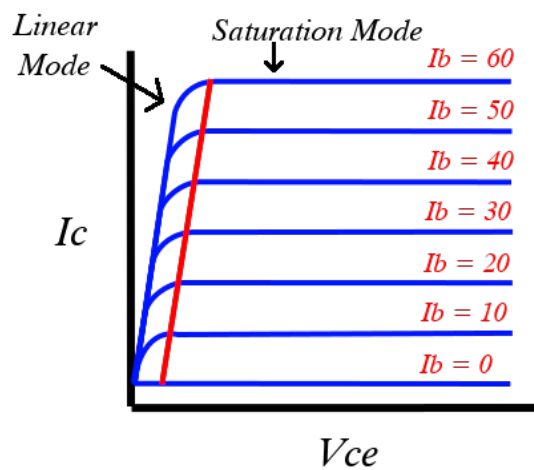

## Circuit Theory & Simulation

We now take these devices and connect them as shown. Consider the below diagram:

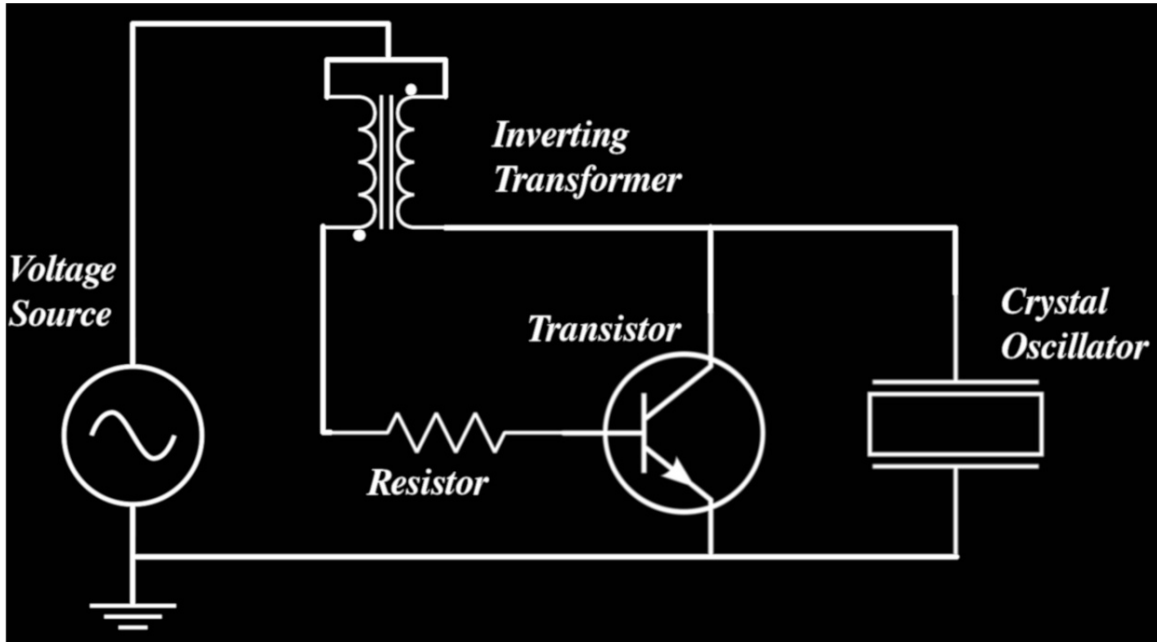

The circuit diagram illustrates the components and internal connections of the Orgone Amplifier. The operation can be compared to a buck boost converter, with 6 basic steps. Step 0 represents the circuit before any energy is applied, step 7 is shown to illustrate the repetition of the oscillations.

The operation of the oscillator can be broken down into 6 discrete states, with an initial Zeroth state, described in the following images.

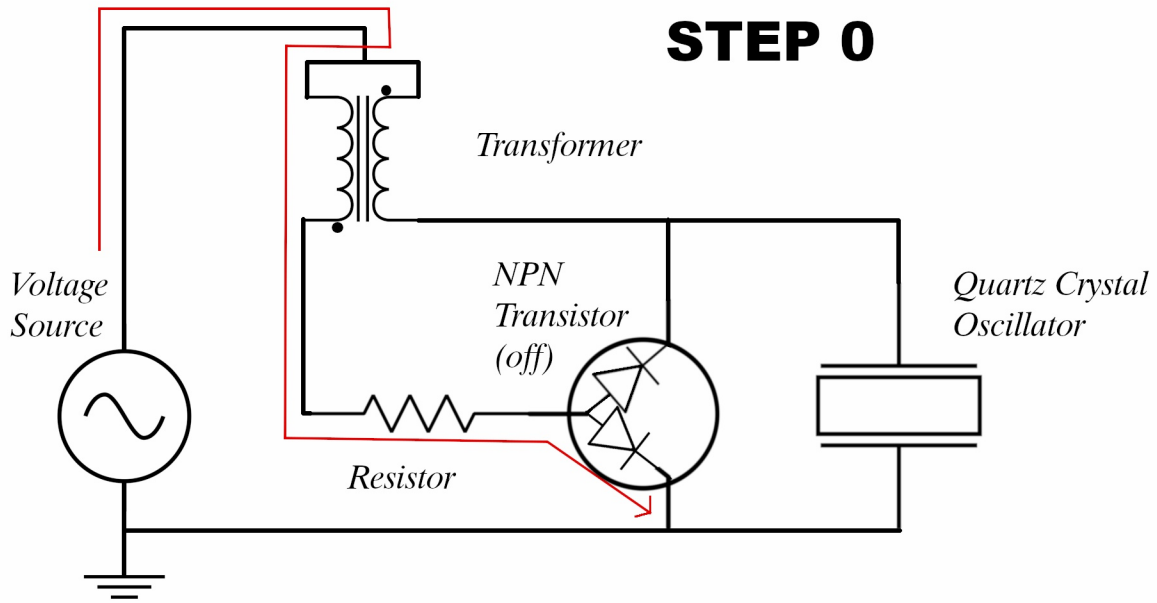

Step 0) This is the initial state of the circuit with no energy. The transistor is in a “normally off” state when there is no energy applied. When some energy is applied, it switches the transistor from an “off” state to an “on” state, and this transitions the circuit into the running oscillations.

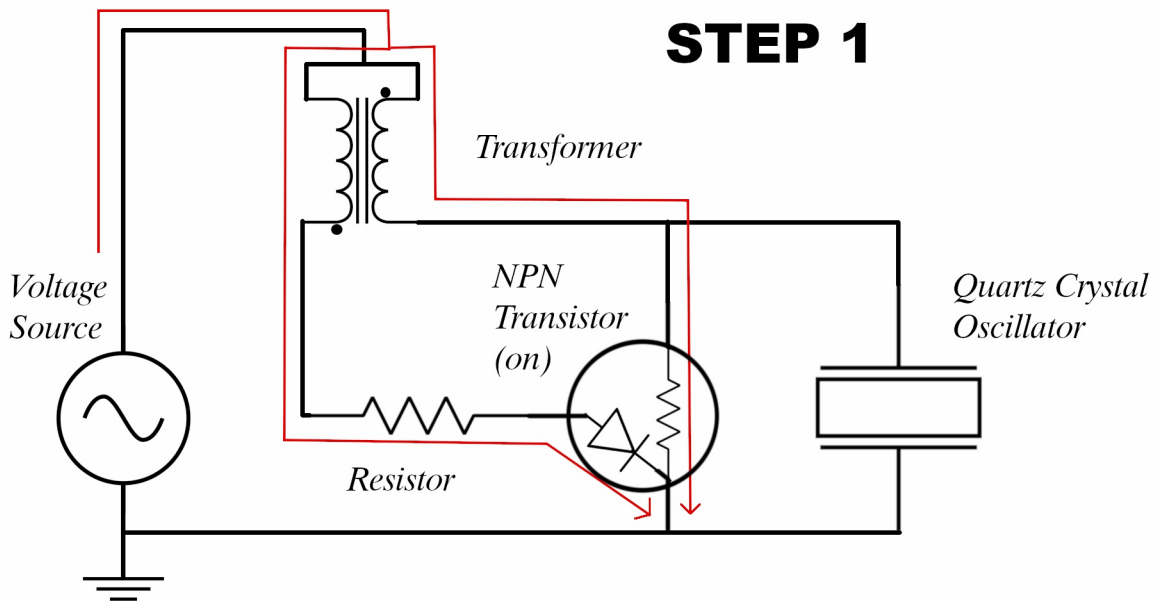

Step 1) The voltage source provides electrical charge to the circuit, shown in the thin red line. The transistor is now in the “on” state, and allows current to pass through.

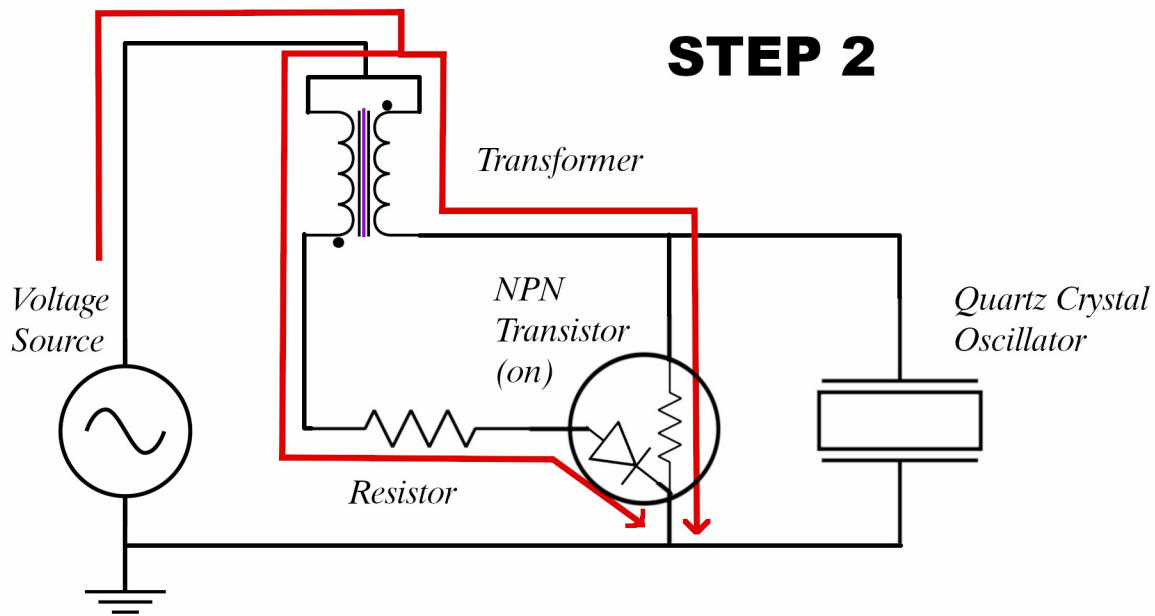

Step 2) The increase in current flow to the crystal sets up an increasing magnetic field in the primary winding of the transformer. Energy from the source is being stored in the magnetic field.

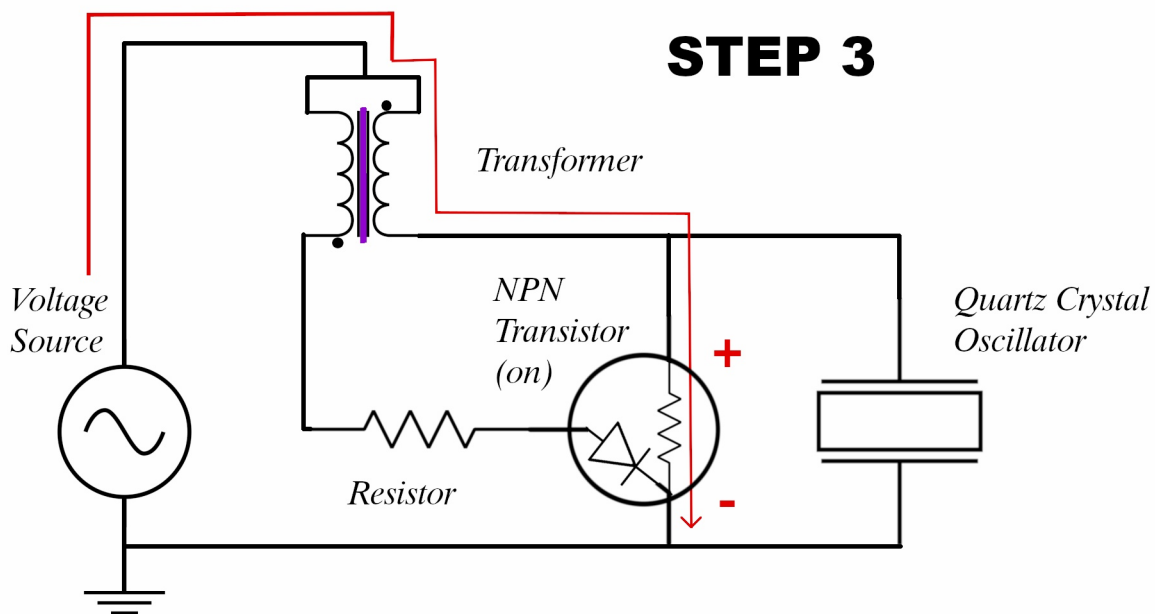

Step 3) There comes a point where the current through the transistor saturates, and the device resists to take additional current. The action of resisting additional current creates a voltage across the transistor, designated by the red plus and minus symbols. This back pressure slows down current through the transformer. There is still energy within the magnetic field, as shown by the purple line through the transformer core.

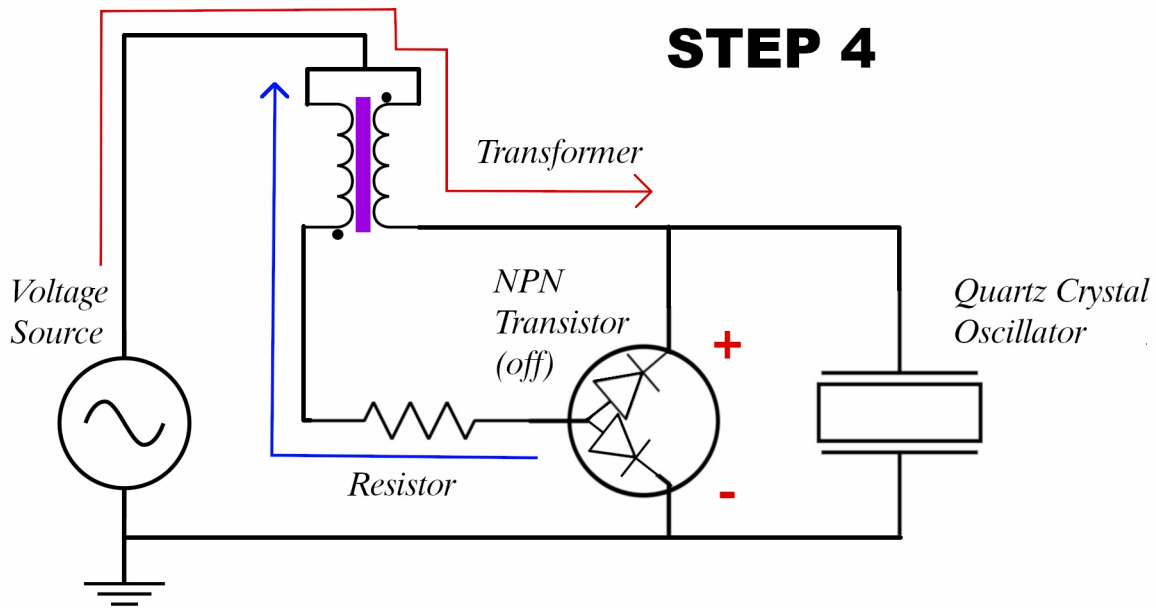

Step 4) The decrease of current through the transistor induces a counter current shown in blue. The counter current is moving up through the transistor, but this is the incorrect polarity according to the internal diode, and the transistor switches to the “off” state very quickly. There is now a very rapidly growing voltage across the transistor and the crystal, with the magnetic field within the transformer reaching a maximum.

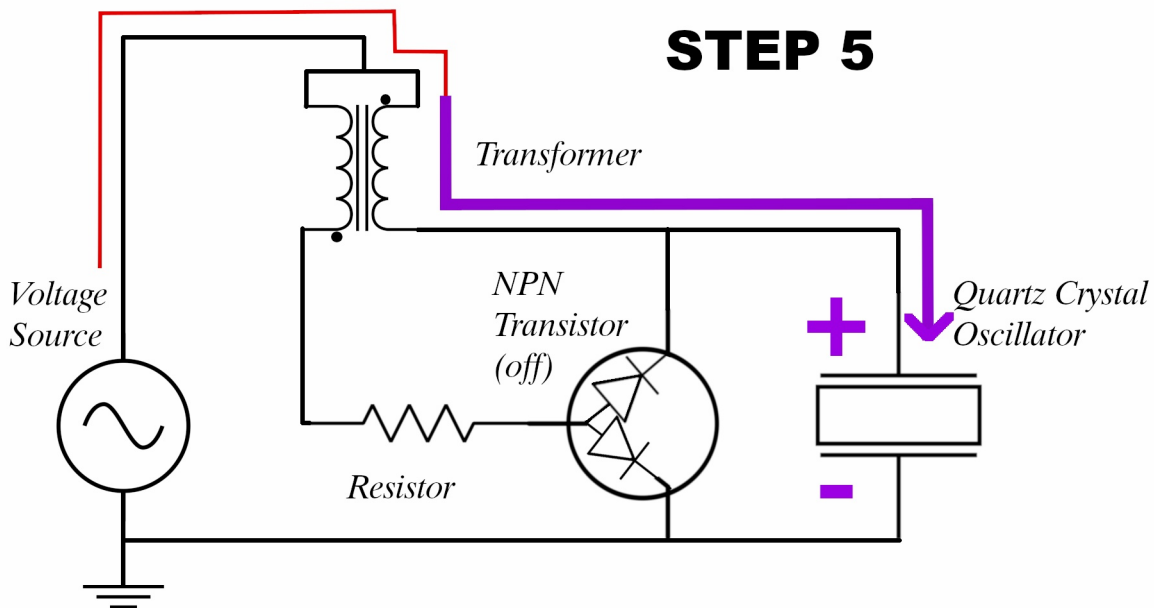

Step 5) The magnetic field stored in the transformer collapses, and adds with incoming red energy to create a very large pulse across the crystal oscillator. Due to the ferocity of the incoming energy, the crystal builds up charge very quickly, attaining voltages many times greater than the incoming energy from the voltage source. The large voltage across the crystal is shown as the large purple plus/minus signs across the crystal emitter.



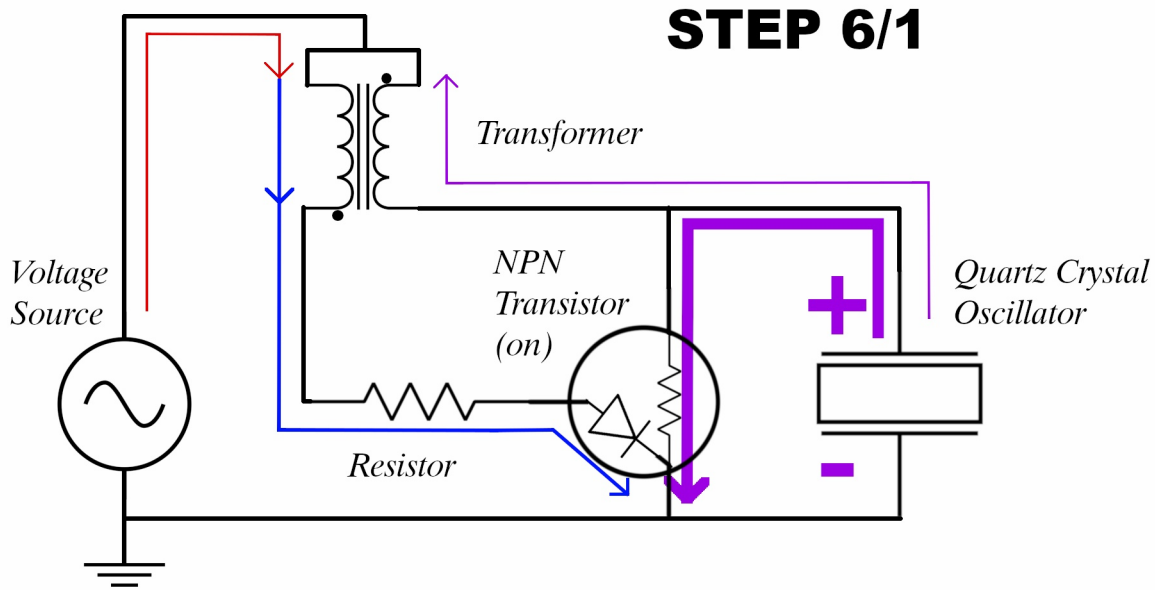

Step 6) There is a couple of things that happen simultaneously in this step, but it is the most important step in the orgone production process. The charge across the crystal hits a maximum and reverses. A small amount of current is sent back to the voltage source. This reverse current induces the blue current downward, in correct polarity according to the transistor. The transistor changes from the 'off' to 'on' state, and discharges the crystal very quickly, as shown by the large purple arrow. The quick discharge of the crystal is **the primary emitter of orgone**, and is the crucial step in producing the desired effect. We label this step as 6/1 because this is also the first step that is repeated in the cycle of oscillations. Step 6 looks exactly like step 1, but while introducing step 1 the crystal was not charged.

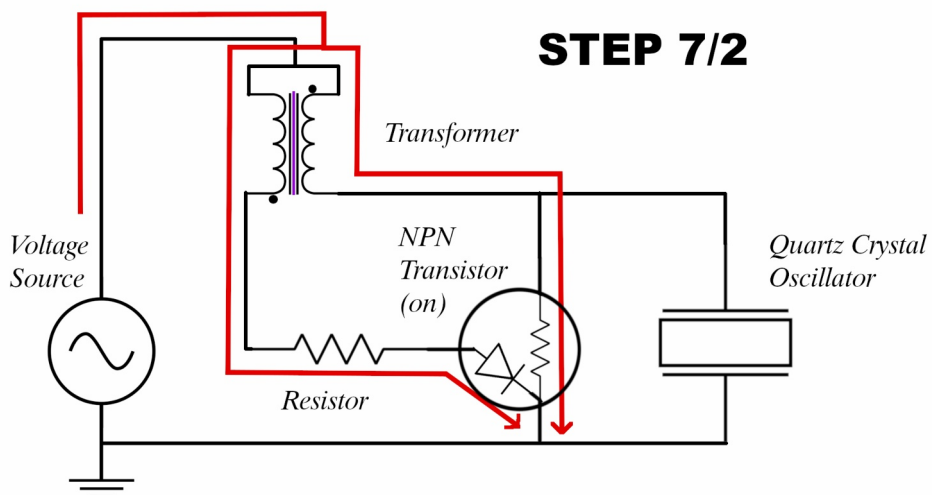

Step 7) Step 7 is included to fully complete the oscillation. Step 7 now looks exactly like step 2. The crystal has discharged, the transistor is on, and the magnetic field is building in the transformer.

Following step 7 is step 3, and the circuit repeats through the steps indefinitely until the source of energy is interrupted. In reality, these steps are almost indistinguishable and the circuit has 2 states, building magnetic field while collapsing the crystal charge, or building crystal charge while collapsing the magnetic field. This process can repeat thousands to millions of times every second.

We take this a step further and create a computer simulation of the oscillator circuit using ideal components described above. For this simulation we use Everycircuit for creating the simulation. We chose a voltage source of 1.5 volts, and below is a picture of the simulation and a signal plot with color coded signals. A link to the simulation is included below:

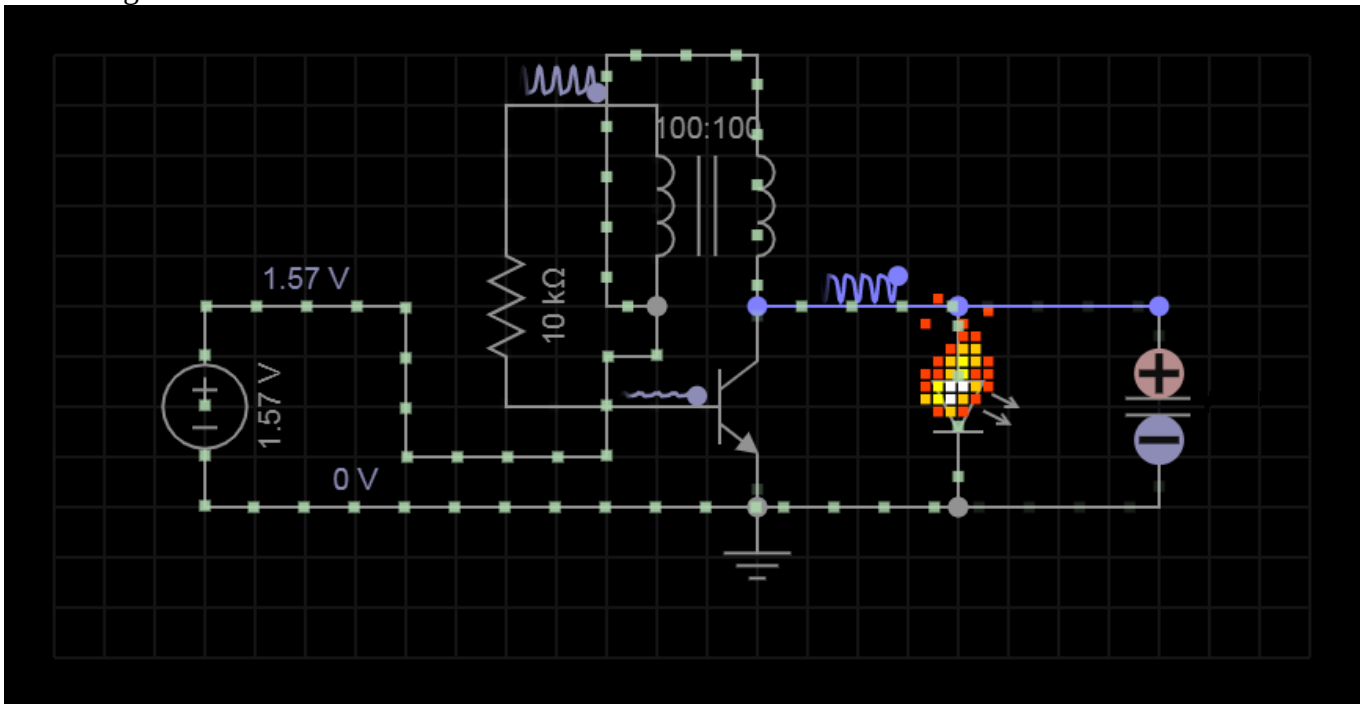

### [OA-1000 Circuit Simulation](#)

It is only through our understanding of the inner workings of each component that we can understand each individual phase of the oscillator. Next we will examine the “Air to electric interface” to understand the source of electrical energy in the RF harvesting circuit.

## Air to Electric Interface

The air to electric interface is a term used to describe an antenna and associated circuitry that receives the incoming electromagnetic wave, matches the impedance of the oscillations and multiplies the incoming voltage to assist in the harvesting effect. We will review the nature of EM waves in free space and review electromagnetism in circuits. We will then extend the circuit to show how antennas receive and transmit electromagnetic waves. We understand the need for impedance matching circuitry and the voltage multiplier. Below is a block diagram of the RF harvesting Orgone Amplifier circuit:

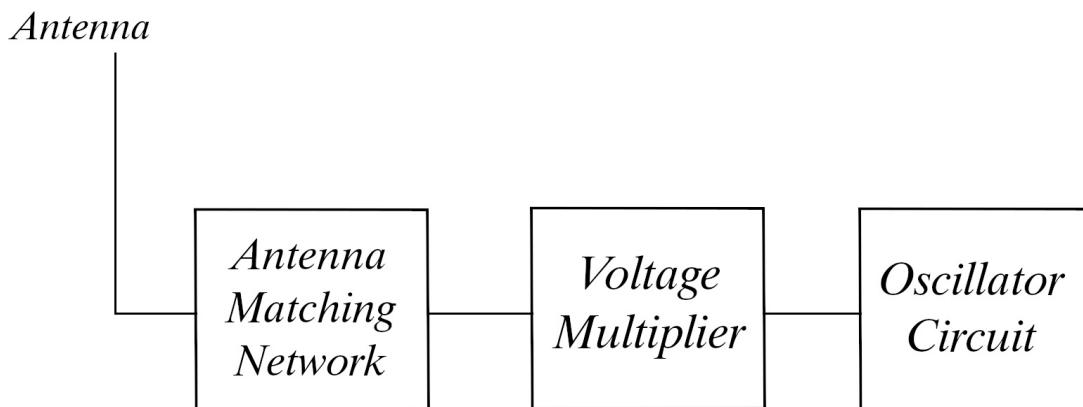

## Antenna Theory

To understand Antennas, one must understand the nature of the sine wave.[3] A sine wave looks like the below graph:

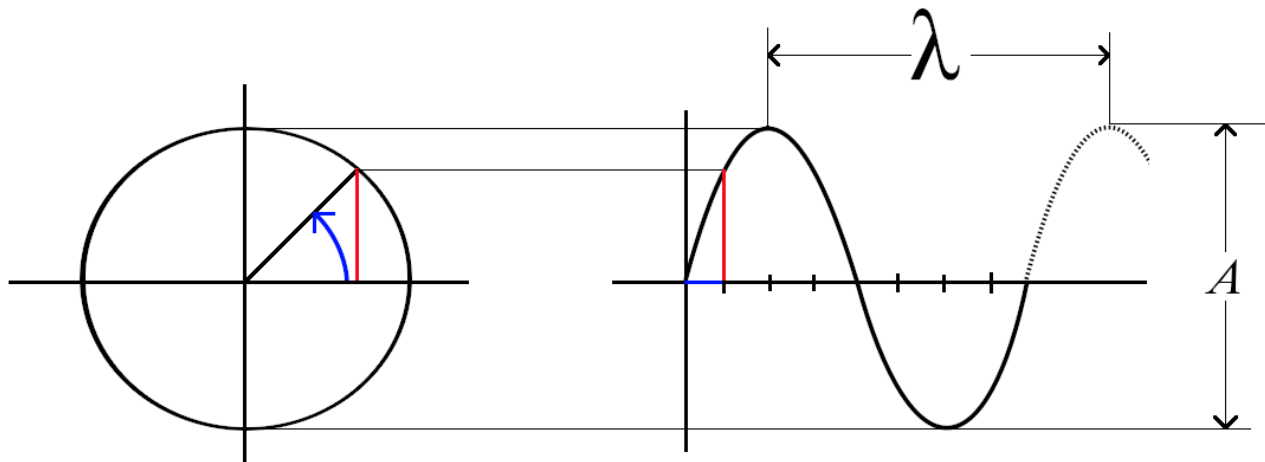

The sine wave has a characteristic amplitude, which is the distance between wave and trough, and a wavelength, which is distance between wave peaks. The graph shows the repeating nature of sine waves, as the black arm spins around the circle in the direction of the blue arrow, the red line shows the value that gets projected on the sine wave graph. When waves travel through a medium they have a

certain speed, and the time it takes for a stationary observer to experience the full distance between waves is called frequency. If the observer experiences 1 Cycle/ Second we call this 1 Hertz.

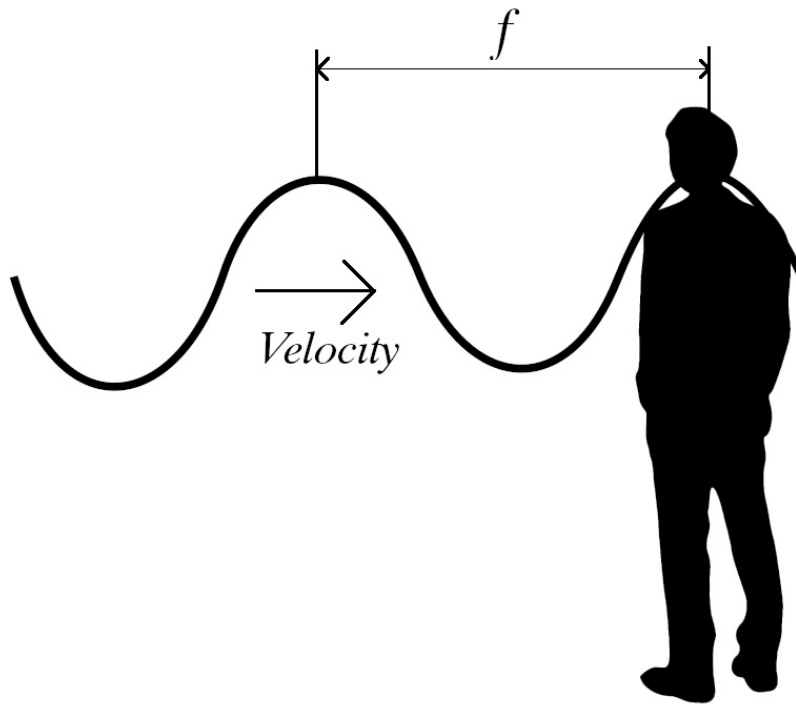

There are two interesting properties of the sine wave that the antenna utilizes. The first is the rate of change, and the second is the ability for any signal to be decomposed into a series of sine waves added together, called Fourier series.[4] An antenna is a device that receives only changing EM fields, therefore the sine wave is the primary waveform that is transmitted and received by the antenna. To understand the antenna, one must understand the nature of changing magnetic and electric fields.

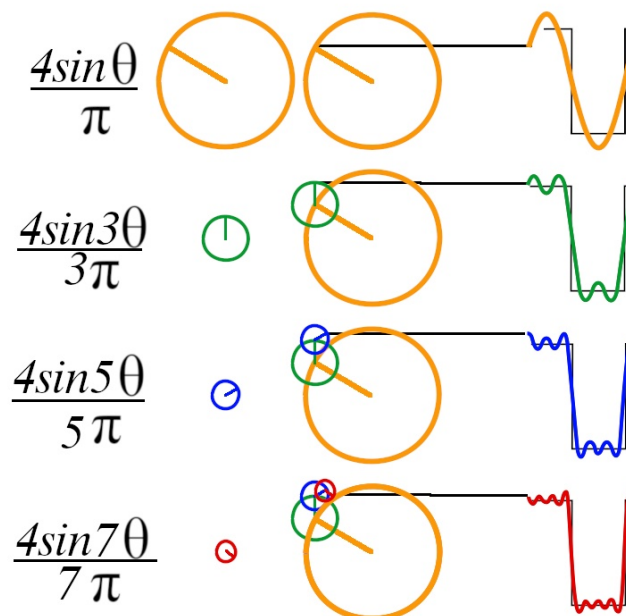

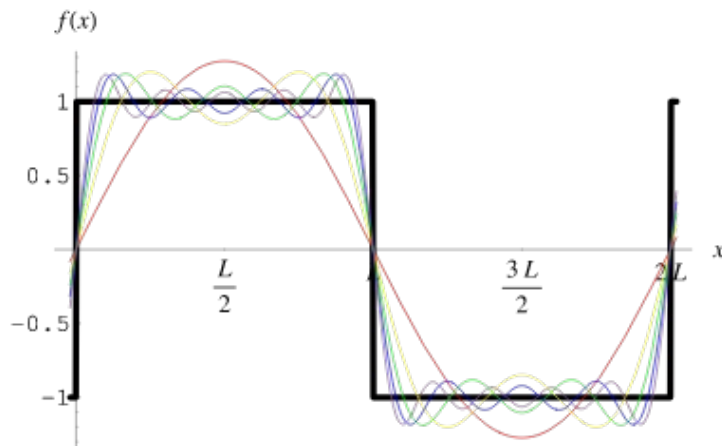

It follows that the ideal antenna can pick up on an infinitely varied signal by decomposing the energy into a series of sine wave frequencies. Shown above is a square wave plot with odd harmonics added together to form a square wave. We can see that as more harmonics are added, the accuracy of the composed signal increases. It follows that **any signal can be reproduced with an infinite number of smaller sine waves**, eventually leading to the final signal. In practice, an antenna does not respond to an infinite range of frequencies, and will pick up on a narrow or broad band of frequencies based on the construction and physical geometry.

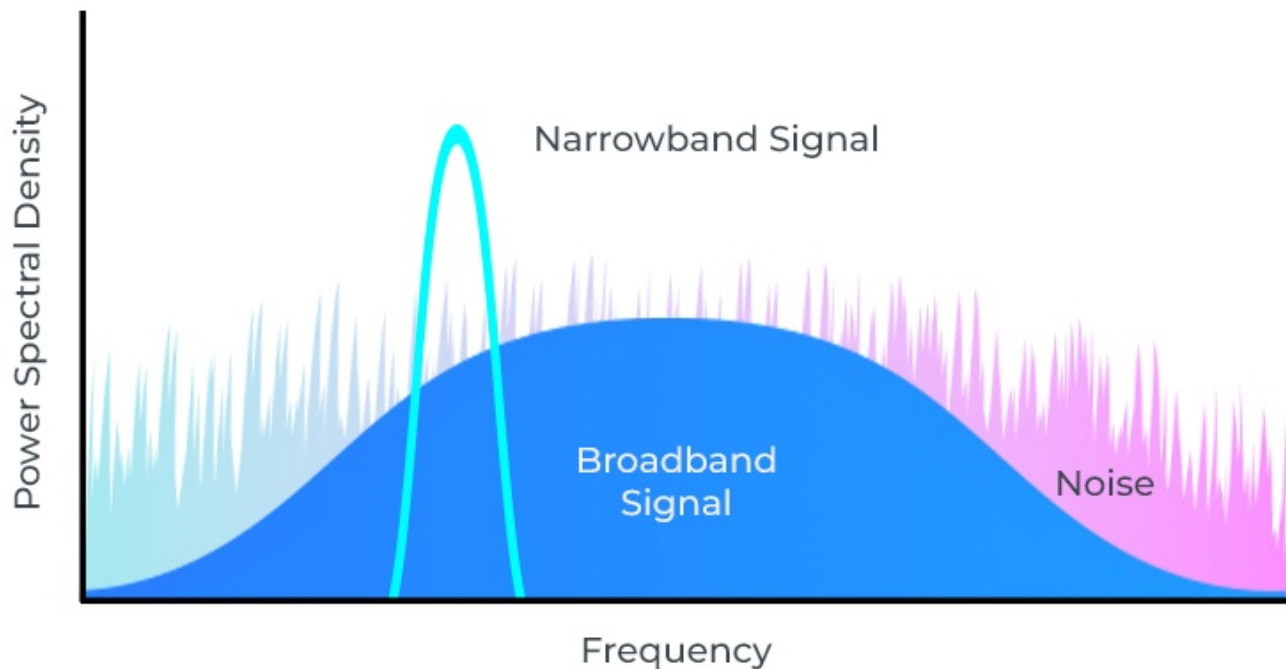

To accurately reproduce a signal with energy spread over a large range of frequencies, multiple antennas of different frequencies are combined to create a multi-band antenna.

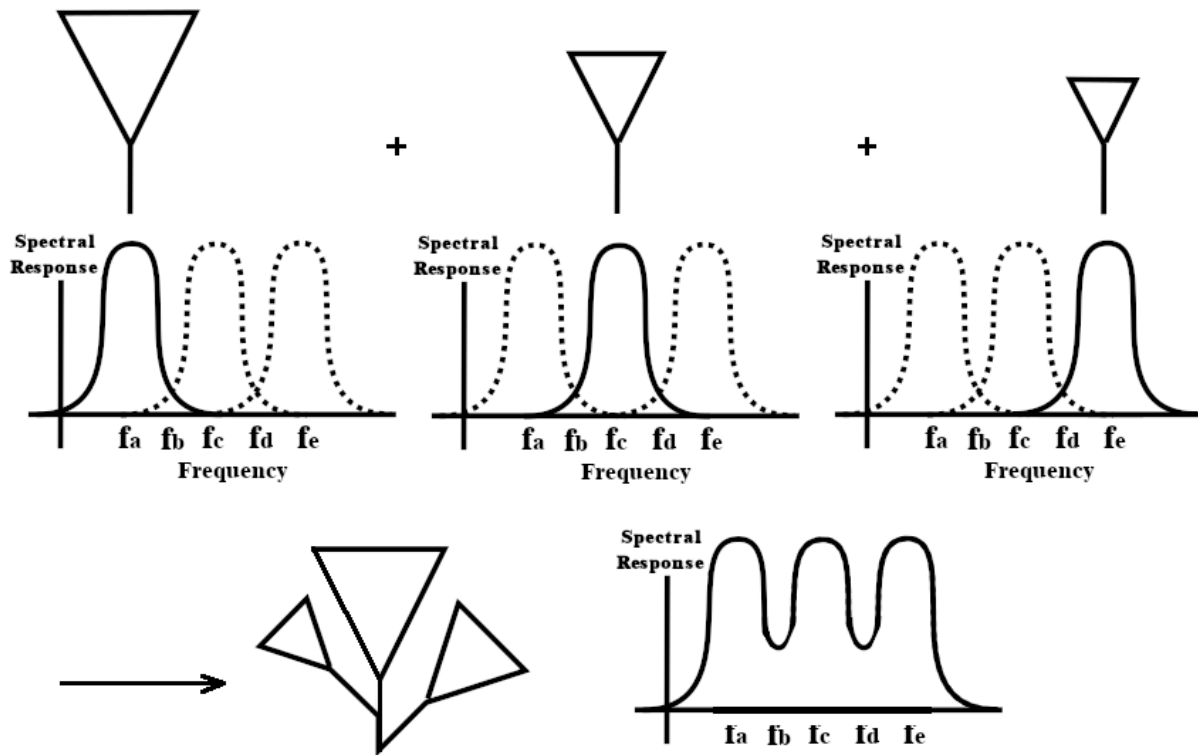

### Electric waves

We mentioned before that Electromagnetic energy can move across a medium in a wave like motion, below is a diagram of an EM wave in free space:

## Electromagnetic Wave

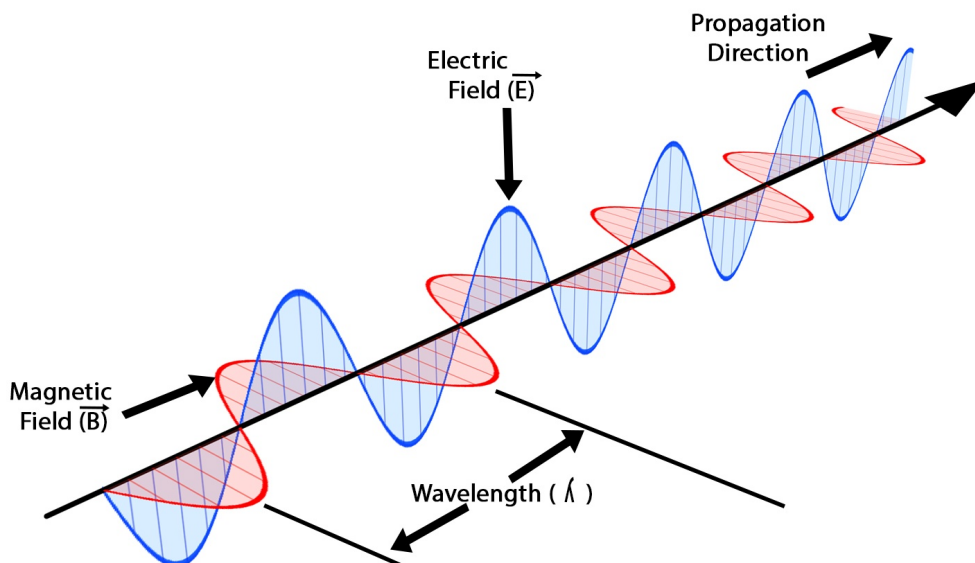

An electromagnetic wave travels at a certain constant speed across free space, called the speed of light. The speed of light is extremely fast, one of the great constants of our universe, and in our number system it can be approximated with the below value:

299,792,458 meters per second (m/s)

Time and frequency are related through the speed of the wave in a medium. The speed of sound in air is about 330 meters/second depending on temperature, pressure and humidity. The formula to relate velocity of the wave, wavelength and frequency is given below:

$$f = \frac{v}{\lambda}$$

This formula describes the inverse relationship between frequency to wavelength when speed is constant. When the speed of a wave in the medium is very fast, **waves of very low frequencies are extremely long**. For example, Earth's electrical resonant frequency, the Schumann resonance, has a wavelength of  $299,792,458 \text{ m/s} \div 7.83 \text{ Hz} = 38,287 \text{ Km}$ , or about 24,000 miles. This is no coincidence that the circumference of the earth is also 24,000 miles, in fact, it is **because** the earth is 24,000 miles, that the resonance frequency is 7.83Hz.

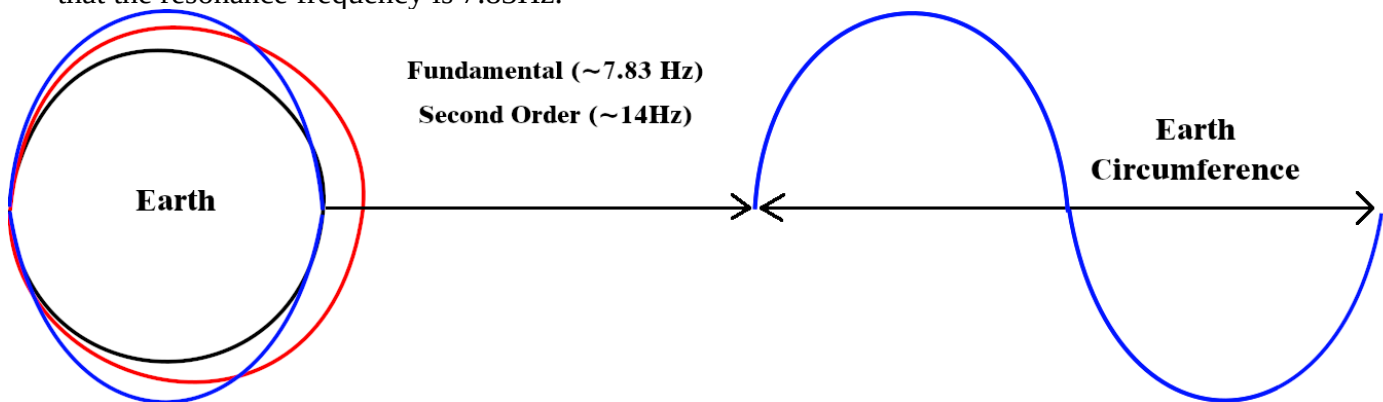

As the frequency of a wave increases, the wavelength decreases. 3G, 4G, WiFi and Bluetooth have wavelengths in the tens of centimeters. 5G is a relatively new technology with a much higher frequency with waves the size of millimeters. The size of 5G waves is the origin of the term “millimeter waves.” Visible Light also is an electromagnetic wave, and the photo receptor cells in the human eye are sized to capture a few wavelengths of the high frequency electromagnetic wave.



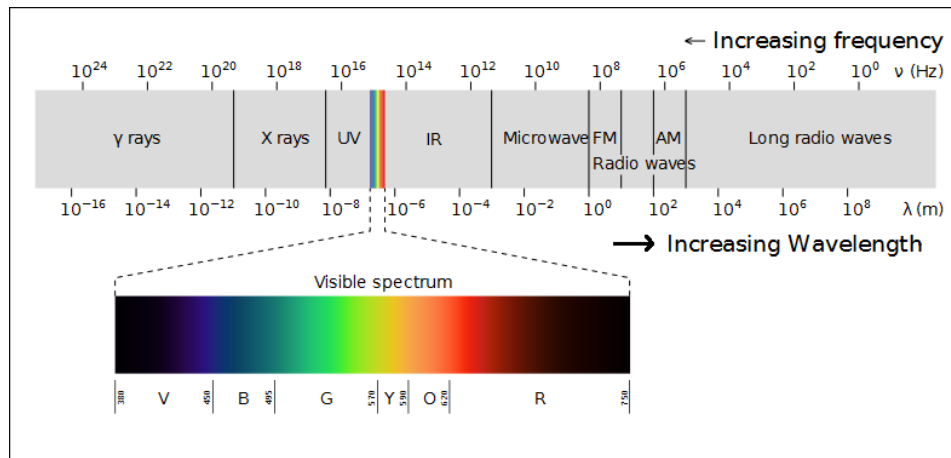

The geometry of the antenna directly corresponds to the frequency and wavelength it is designed to most efficiently capture, as we will explore in the next subsection.

### Simple RF Circuit

An antenna has the property of reciprocity, which means that it is an effective structure for both the receiving and transmitting of em waves. **We can understand how effective the device is receiving EM waves by examining how an antenna transmits EM waves.**[5] Observe the below simple circuit:

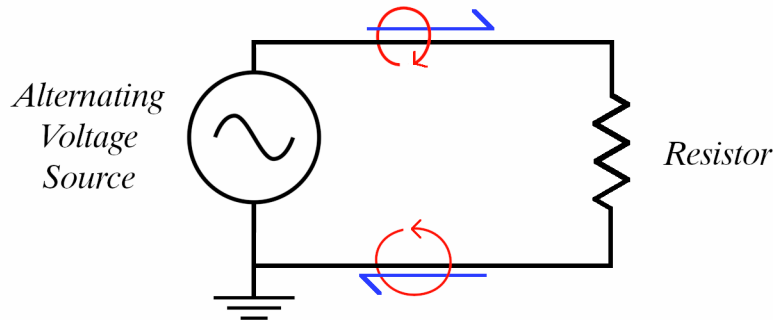

The above diagram shows the direction of current flow in this circuit represented in blue. The movement of charges **within** the wire causes a magnetic field to form **around** the wire in the direction noted by the red arrow. We denote this convention by using “the right hand rule,” visualized below. The right hand rule states that the magnetic field will curl in the direction of your index finger when pointing the thumb in the direction of electric current flow.

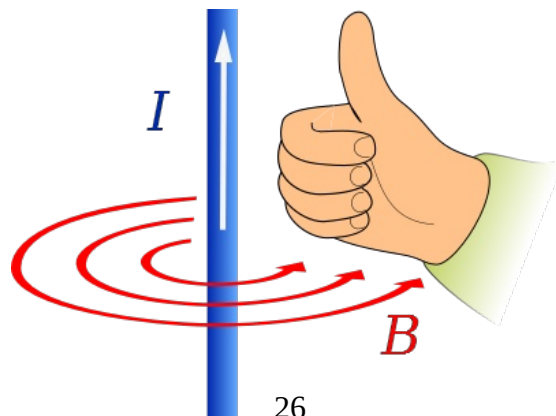

We use the right hand rule convention to show how fields are oriented when a known direction of electric current is flowing through a wire. Recall a middle school science experiment where iron filings are placed around a wire:

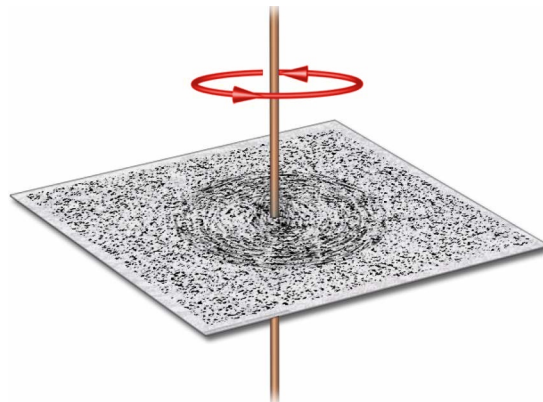

When electric current is run through the wire at the center of the cardboard plate, the iron filings align to the circular magnetic field lines surrounding the wire. We take this simple experiment and extend it to our simple circuit with field lines pictured below:

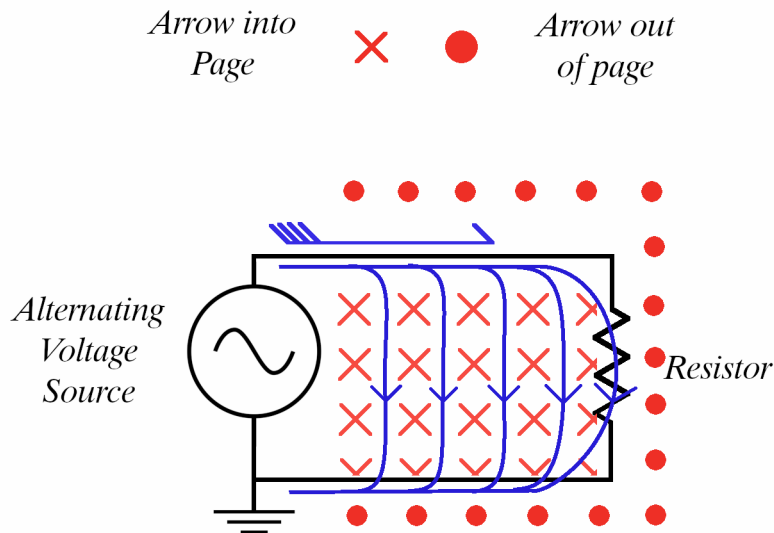

Above we see a 2 dimensional representation of the fields within our simple circuit. The blue field lines are the electric field, while the red dots and crosses represent the magnetic field lines. The magnetic field lines when represented on a 2D plane are entering and exiting the page, so are represented as dots and crosses. To understand more completely how the field lines are arranged, we will take a cross section of the fields, looking into the alternating voltage source.

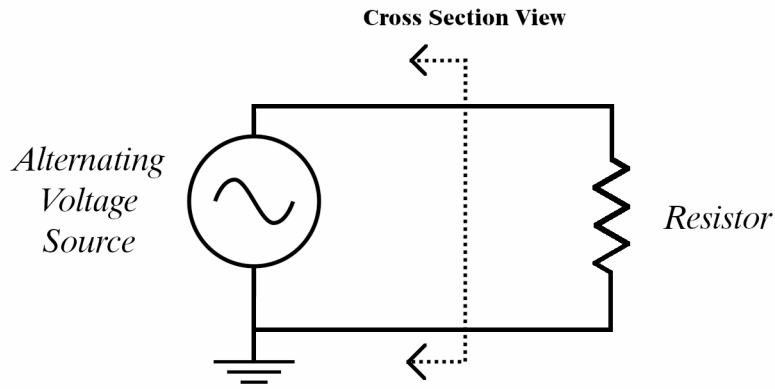

Cross section of fields, looking down the circuit towards the voltage source.

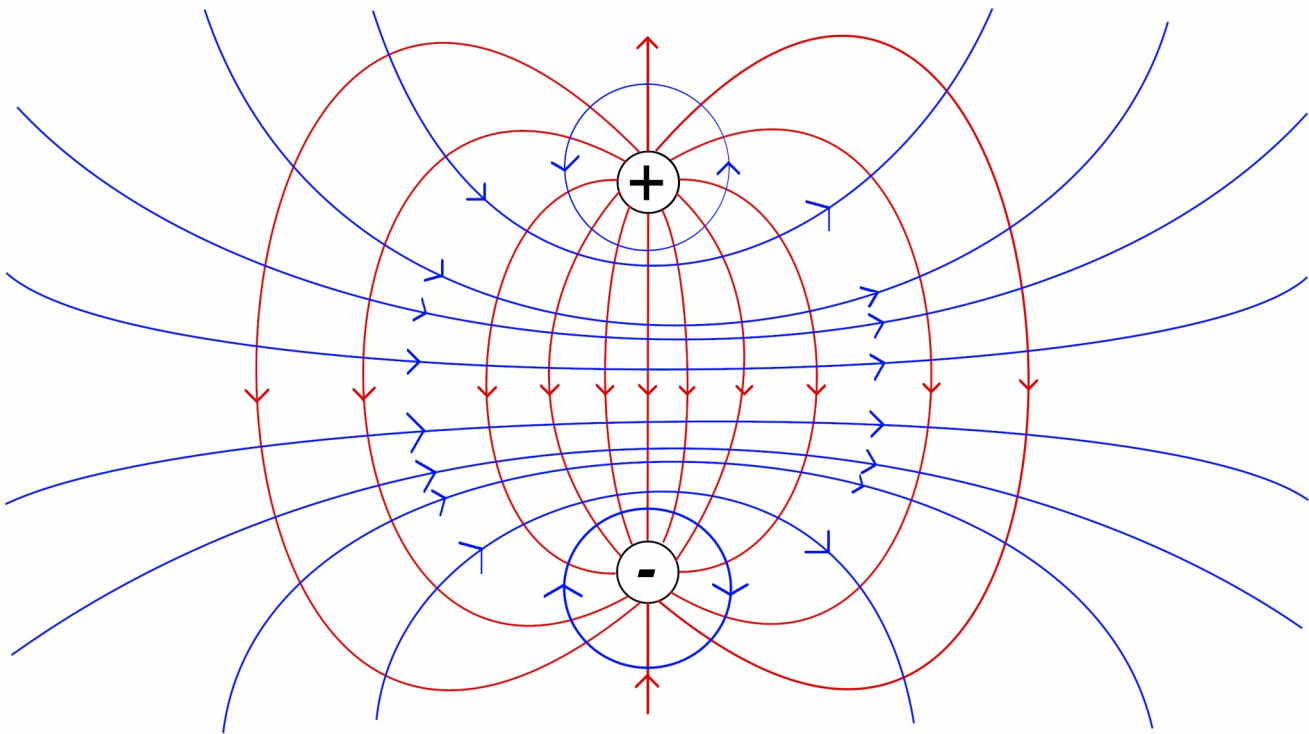

We represent the electric field as red lines which originate from positive charges and terminate to negative charges. Magnetic field lines in theory only terminate to themselves, and form loops as can be seen around the positive and negative wires. The above representation is only during the positive voltage portion of the sine wave. During the negative section, charge flows the opposite way around the circuit and the field lines reverse direction.

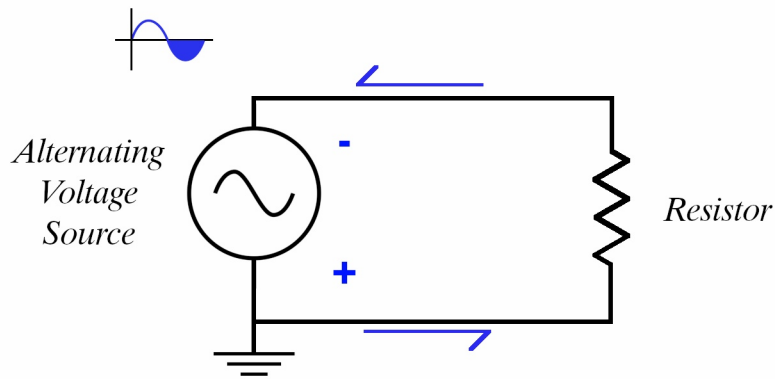

Curiously, even though the flow of charges reverse, energy is still flowing in one direction from source to load. We can visualize this as the source sending waves of field energy to the resistor, and the resistor dissipates this energy as heat.

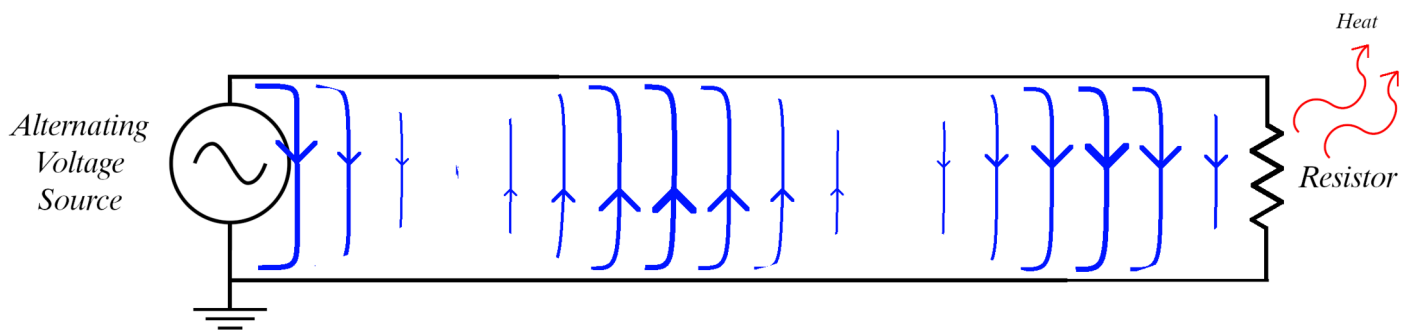

To understand the operation of an antenna, we must separate the source and the load by a distance, at least 1x the wavelength of the source oscillations. When the source and load are sufficiently separated, or the source frequency is very fast, transmission line effects are introduced into the circuit. For frequencies that are very low such as 60Hz, the wavelength is very long and transmission line effects do not occur unless source and resistor are separated by thousands of miles. Radio frequencies that are sufficiently fast require only tens of centimeters to induce transmission line effects. Below is a diagram of the electric and magnetic fields in a circuit where the source is sufficiently separated from the load:

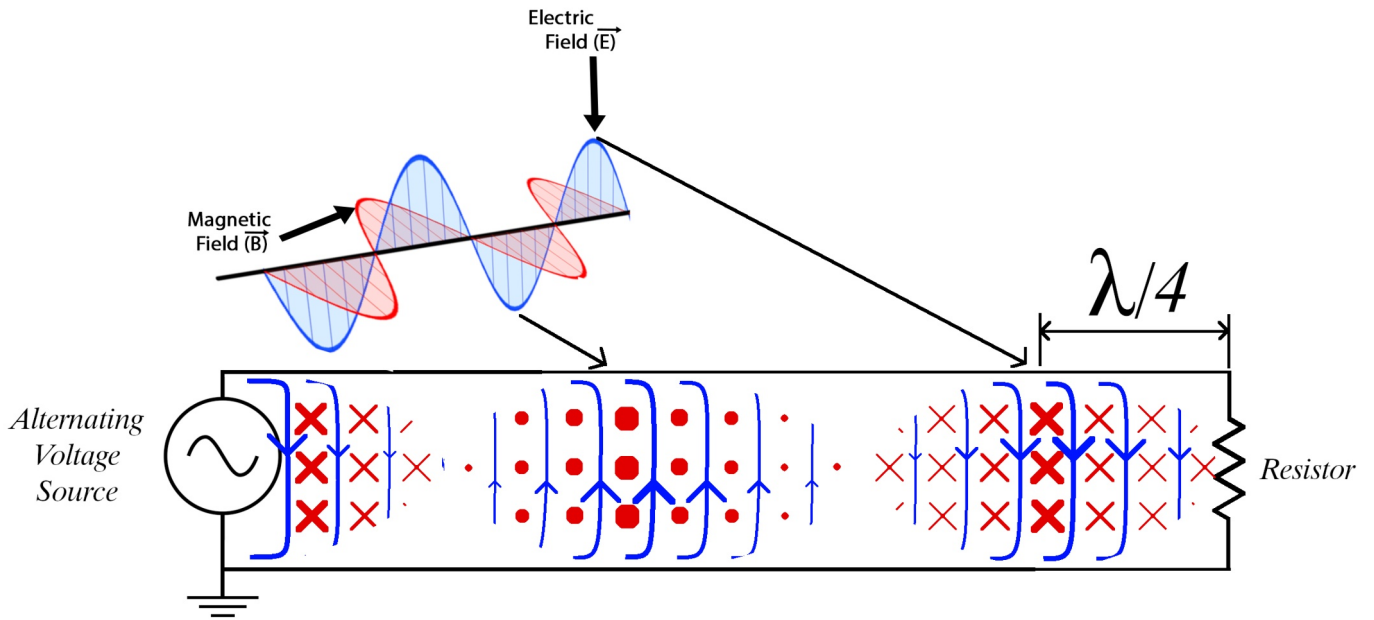

From this diagram we can see that this two wire structure acts like a guide for the electromagnetic waves, so we refer to this structure as a waveguide. The two wire structure guides the waves to the load, where the energy is dissipated as heat. In RF circuits, this resistor represents **dissipated electromagnetic radiation** instead of heat, and the resistor can be replaced with two wires, representing the antenna. Below is a diagram of our transmission line waveguide and antenna:

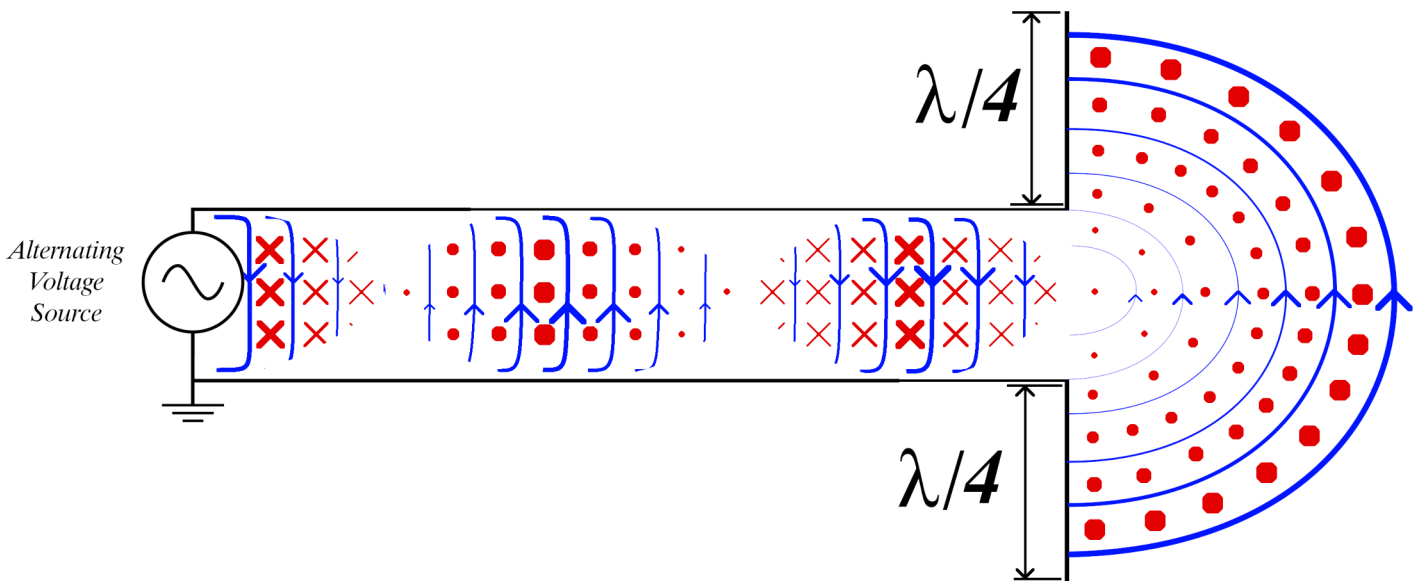

This image shows the alternating current source and the new load, which is a dipole antenna. The length of the antenna is directly dependent on the wavelength of frequency of interest, due to the

relationship of frequency & wavelength. If we design our antenna to be the full wavelength, the zero crossings of the sine wave would create areas of the antenna that do not radiate at all, or do not receive any EM energy.

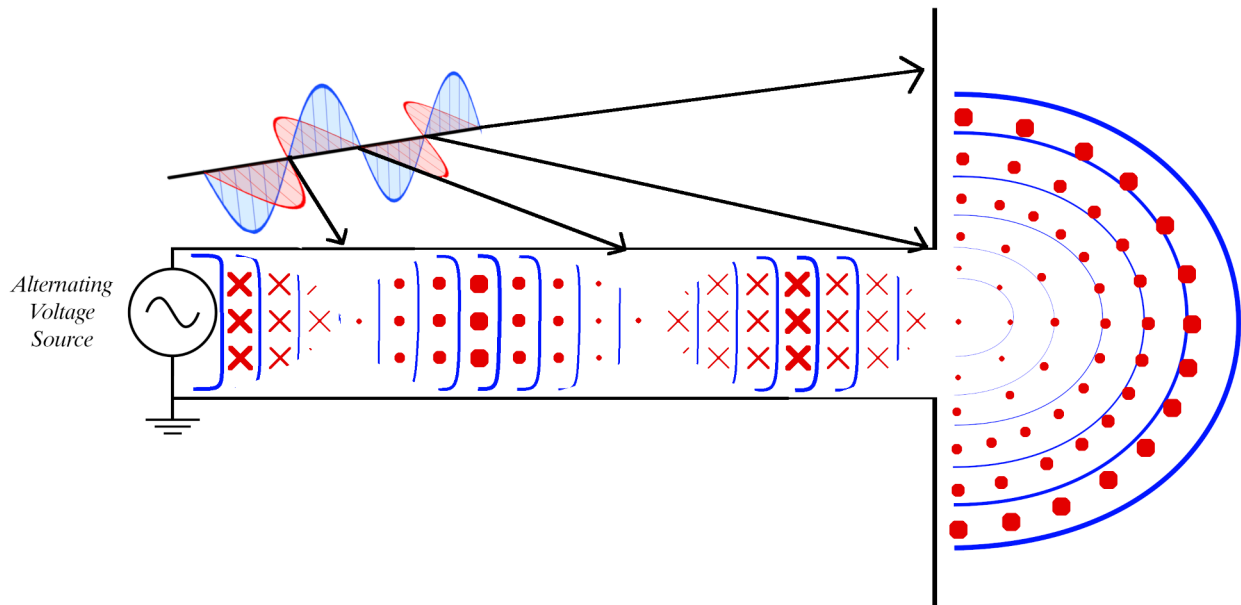

To create the most effective design, a dipole antenna is designed to be  $\frac{1}{2}$  the wavelength of the frequency of interest, with each leg being  $\frac{1}{4}$  of the total wavelength. The dipole antenna is a well studied structure, and below is an example antenna and a 3D diagram showing the intensity of the radiated electric field.

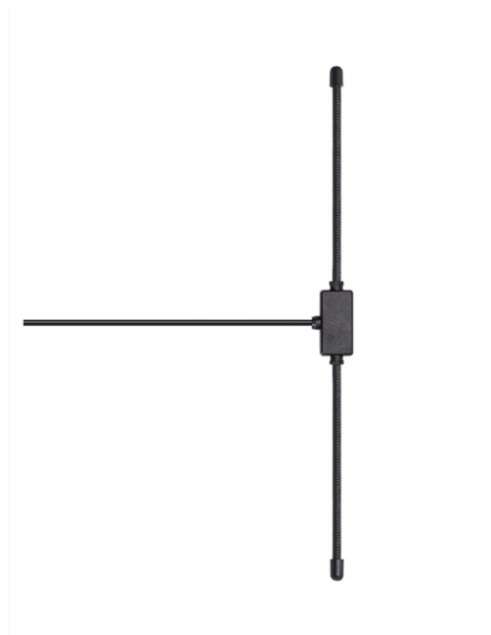

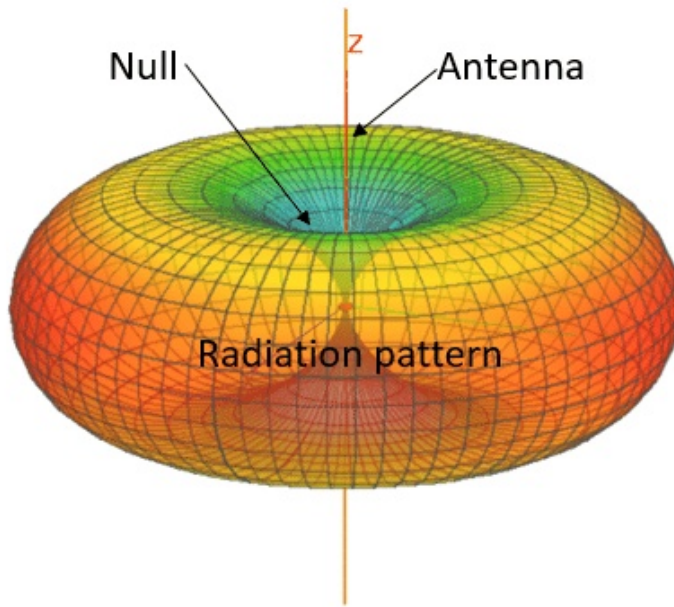

As mentioned earlier, an antenna has the property of reciprocity, so an effective radiator at a certain wavelength is also an effective receiver at a certain wavelength. We extend this idea to analyze an antenna invented by Tesla's counterpart, Marconi. The Marconi quarter wave antenna is an extension of the dipole antenna but using the earth's ground plane to substitute as one of the legs of the dipole.

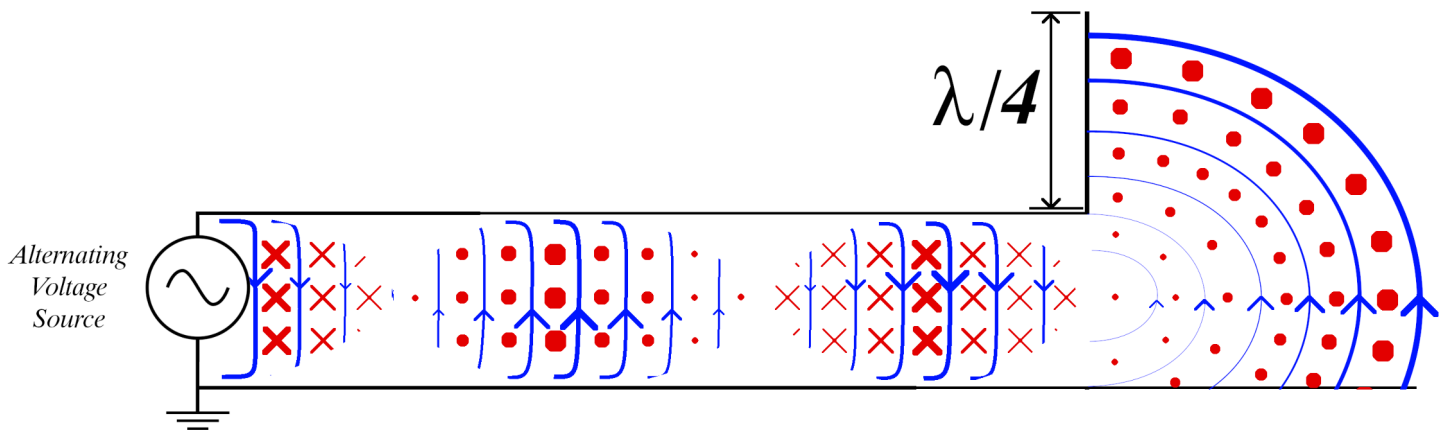

By using the ground plane of the earth, waves that propagate along the surface can be captured with near efficiency of the dipole antenna. The next page shows a diagram of the quarter wave antenna:



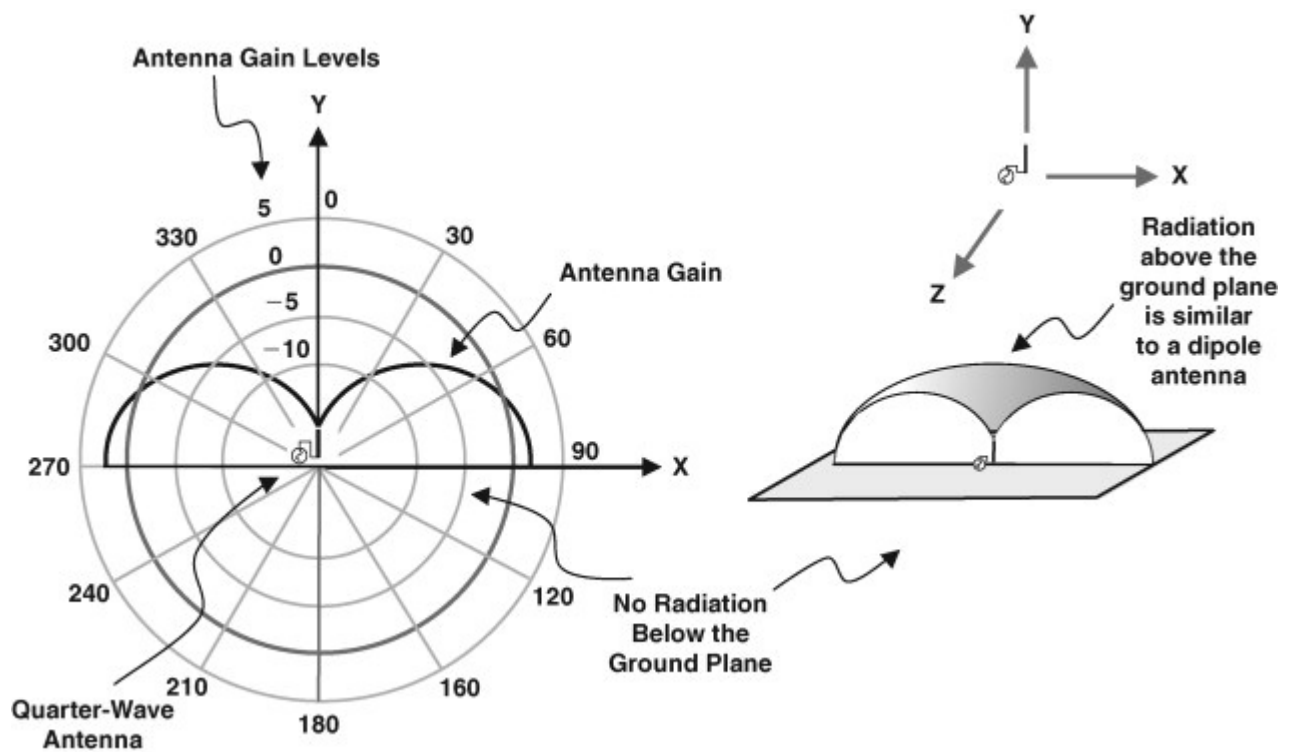

The quarter wave antenna radiation pattern extends in 3 dimensions, with the weakest reception directly above the antenna and the greatest reception perpendicular to the antenna. This antenna is nearly isotropic, which means it picks up energy from all around, but at somewhat of a reduced efficiency. Compare this to a highly directional dish antenna, which captures a large surface area of EM waves, and focuses the energy very finely on the sensor. An isotropic antenna will have a 0 dBi gain, where a highly directional dish or patch antenna might have a gain from +9 to +14 dBi. This means the dish antenna is 8-25x as effective at capturing RF power compared to an isotropic antenna. The trade off is that the dish must be pointed very precisely at the radiating EM source, or it captures very little signal power. Below is a dish antenna and the reception diagram.

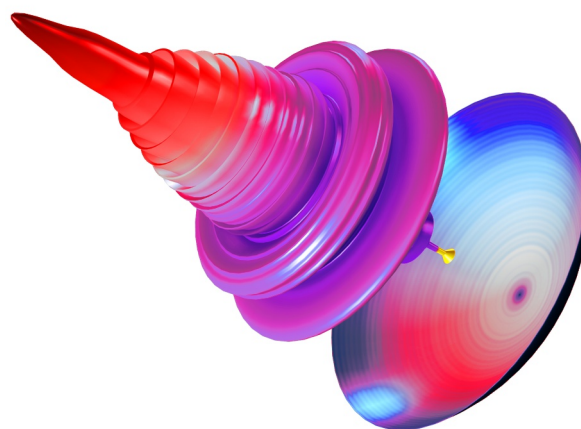

The Orgone Amplifier can have any number or variety of antennas based on user preference and environment. The antennas for the Orgone Amplifier have been selected to be quarter wave antennas tuned to RF + Microwave frequencies, with extended capabilities into the 5G frequency realm. To capture the widest range of frequencies with greatest efficiency, impedance matching features are designed into the device with techniques described in the following sections.

Now that we understand the construction and operation of an antenna, we look at the circuitry that allows the most optimal transfer of power from an antenna to usable currents and voltages. The next section is dedicated to building the impedance matching network.

### **Impedance Matching Circuitry**

The Impedance Matching Circuitry and Voltage Multiplier Sections can be skipped if not building a RF harvesting OA circuit. Readers that are not building an OA circuit can skip to the section that details advantages of the Orgone Amplifier and defense of the novelty.

To properly capture EM waves, we must match the antenna to the oscillator circuitry. For the optimum transfer of power the antenna, voltage rectifier and oscillator circuitry must be impedance matched. Below is a diagram of a simple circuit which will be used to explain the maximum power transfer theorem:

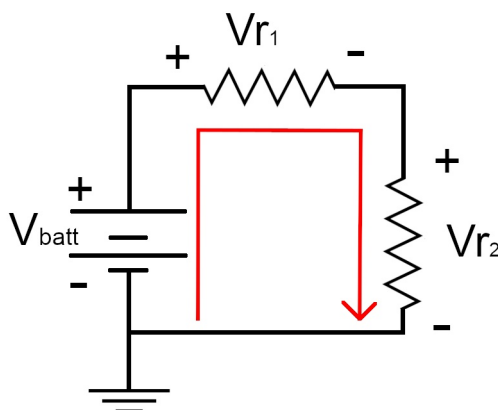

In a simple circuit with two resistors, one resistor represents the internal resistance of the voltage source, while the second resistor is representative of the OA circuit. To define the KVL equations, we start at the ground voltage and follow the arrow around the circuit. The KVL arrow first hits the negative node of the battery, so the first term is  $(-V_{batt})$ . The next voltage that the arrow hits is the voltage across resistor 1, so the next term is  $(+V_{r1})$ . The final voltage that the arrow hits before ground is  $(+V_{r2})$ . The KVL arrow terminates at the ground level, so all terms must add together and equal zero. Below is the KVL equations that define the circuit:

$$0 = (-V_{batt}) + V_{r1} + V_{r2}$$

Ohms law states that the voltage across the resistor is equal to the current through the resistors, so we must find the current through both resistors by adding the resistance together. Resistors in series add together to look like the diagram below.

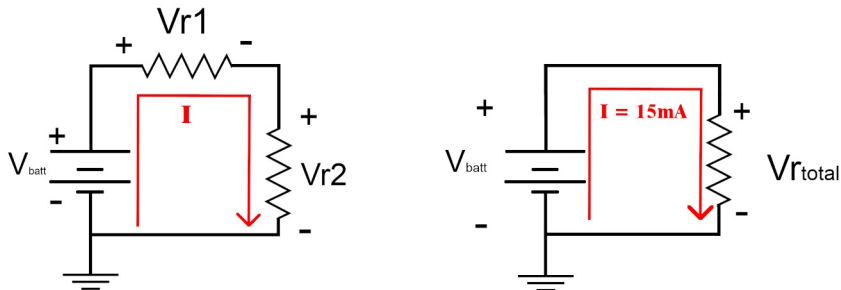

$$R1 + R2 = R_{total}$$

$$(50 \text{ ohms} + 50 \text{ ohms}) = 100 \text{ ohms}$$

#### Ohms law

$$\text{Voltage} = \text{Resistance} * \text{Current}$$

$$V_{batt} = (R1 + R2) * \text{Current}$$

$$\text{Current} = V_{batt}/(R1 + R2)$$

$$V_{batt} = 1.5V$$

$$\text{Current} = 1.5/(50+50) = 0.015 \text{ Amps}$$

$$\text{Voltage across } R1 = R1 * \text{Current}$$

$$\text{Voltage across } R2 = R2 * \text{Current}$$

$$V_{r1} = 50 \text{ ohms} * 0.015 \text{ Amps} = 0.75V$$

$$V_{r2} = 50 \text{ ohms} * 0.015 \text{ Amps} = 0.75V$$

Electrical power is measured in watts, and in a DC circuit, Power = Voltage \* Current

Therefore, the power dissipated by R2 = 0.75V \* 0.015A = 0.01125 Watts.

These two resistors are matched, both are 50 ohms, so therefore 0.01125 Watts is the maximum power in Resistor 2. This can be proven by varying the resistance of R2.

If we were to **change the resistor to a higher value, say 60 ohms**, lets calculate the new power.

$$50 \text{ ohms} + 60 \text{ ohms} = 110 \text{ ohms}$$

$$V_{batt}/110 \text{ ohms} = 1.5V/110 = 0.01363 \text{ A}$$

$$V_{r2} = 60\text{ohms} * 0.01363 \text{ A} = 0.818 \text{ V}$$

$$\text{Power in R2} = 0.818\text{V} * 0.01363 \text{ A} = \mathbf{0.1115 \text{ Watts}} > \mathbf{0.01125 \text{ watts @ 50 ohms}}$$

Curiously the resulting power is less than when the two resistors are identical. We **repeat the calculation with R2 as a 40 ohm resistor**

$$50 \text{ ohms} + 40 \text{ ohms} = 90 \text{ ohms}$$

$$V_{\text{batt}}/90 = 1.5\text{V}/90\text{ohms} = 0.0166 \text{ A}$$

$$V_{r2} = 0.0166\text{A} * 40 \text{ ohms} = 0.66\text{V}$$

$$\text{Power in R2} = 0.66\text{V} * 0.0166 \text{ A} = \mathbf{0.0110 \text{ Watts}} > \mathbf{0.01125 \text{ watts @ 50 ohms}}$$

This result is also a lower power than when using a 50 ohm resistor as R2, therefore **the most power is transmitted from source to load when both the impedances are matched**. To transfer the optimum amount of power from the antenna to the oscillator circuit, we must match the voltage multiplier and oscillator circuit to the 50 ohm antenna. The impedance matching network is somewhat of a complex mathematical task, so to realize the values of our circuit we use special circuit techniques. Below is a diagram of the chosen circuit topology. We chose an L circuit topology for this application as described in the below diagrams:

### *L Circuit High Pass*

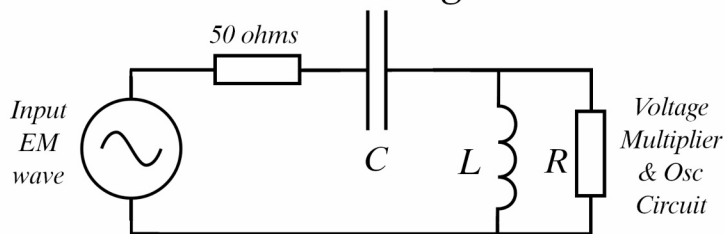

### *L Circuit Low Pass*

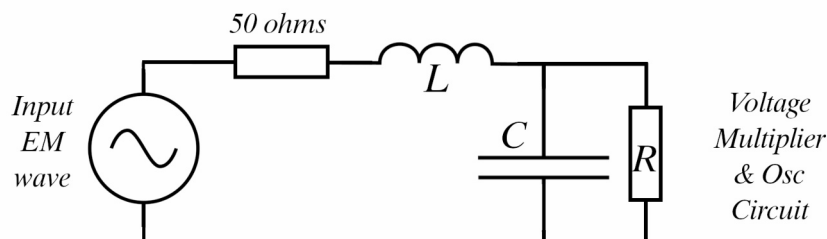

The above diagram shows two configurations of the L circuit, high pass configuration and low pass configuration. We use both configurations in the Orgone amplifier circuit but use the high pass configuration for the OA-100/1000 example circuit. The three values of interest in the matching circuit are L, C and R. To find the values of L and C, we must first understand the impedance of R, which is representative of the voltage multiplier and OA circuit.

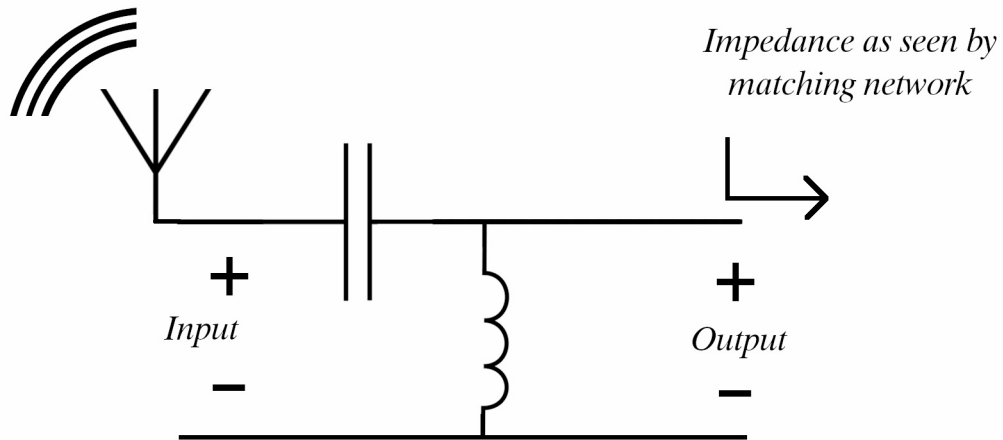

**Voltage Multiplier**

After the EM wave is harnessed by the antenna and rendered into usable currents and voltages, we use a voltage rectifier/multiplier to pump charge to a voltage up to 4x greater than the input. This allows the harvested EM energy to be utilized in the Orgone Amplifier Circuit. The voltage multiplier is based on the half wave Cockcroft-Walton multiplier, which uses an alternating current to pump charge to a higher potential. Below is a diagram of the multiplier circuit:

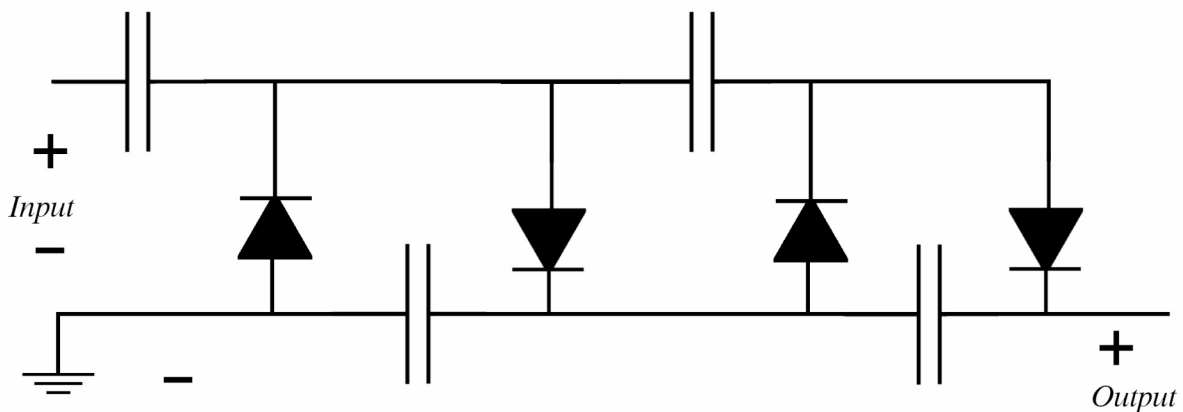

Remember the internal operation of the diode lets charge through in one direction, and this effect is crucial for the operation of the charge pump. The multiplier circuit uses the positive section of the sine wave to push charge from one capacitor to the next, with the diodes preventing charge from reversing. Crucially for RF harvesting, the diodes need to have the lowest possible activation voltage, so for this application we choose schottky diodes similar to those chosen in [6], which have a forward voltage as low as 150mV.

An in depth analysis of the voltage multiplier can be found in [7]. The important finding is that the capacitive component of the multiplier network input impedance is largely due to the effect of the capacitors in series. Capacitors in series add differently than resistors, and we can calculate the total capacitance by the below formulas:

$$C_{total} = \frac{1}{\frac{1}{C1} + \frac{1}{C2} + \frac{1}{C3} + \frac{1}{Cn}}$$

$$Xc = \frac{1}{\omega \cdot C} = \frac{1}{2 \cdot \pi \cdot f \cdot Ctotal}$$

$C_{total} = 1 / ((1/ 10nF) + (1/10nF) + (1/10nF) + (1/10nF)) = 2.5 \times 10^{-8}$  Farads. Using a center frequency of 910 MHz, common for Bluetooth and cellular devices, our  $Xc = 1 / (2 \cdot \pi \cdot 910e6 \cdot 3e-8) = 0.0058$  Reactive ohms. We can use this formula to calculate the reactive impedance over a wide range of RF frequencies to alter the impedance network for antennas of different center frequencies. Calculating the capacitors in series gives one component of the impedance, but we still need the restive component, which is difficult to define due to the non linearity within the diodes of the voltage multiplier circuit. What we do instead is choose a diode with an optimal turn on curve, calculate the range of resistances over the input signals as described in [8] and then create a matching resonance circuit to produce an input voltage suitable to create the ideal 50 ohm match. By examining the diode's datasheet, we find the forward resistance of the diode could be anywhere from 2400 Ohms to 40 Ohms. We find the diode provides an optimum 50 ohm impedance match when 300mV is produced by the 50 ohm antenna and impedance matching network. This is an excellent result, as a matched impedance allows the maximum power to be transmitted to the oscillator circuit with only an isolation capacitor needed to counter balance the capacitance in the voltage multiplier stage. With a matched voltage multiplier, the RF harvesting circuit is able to receive the maximum range of frequencies available to the antenna.

To reduce the effect of capacitance on the matching network, the active OA-1000 circuit can benefit from inductor coils. Finding parts at the values we need is often a challenging task, so we can create a small inductance by coiling insulated wire. We use 20 gauge enameled wire and cut the wire to specified lengths according to the tests done in [9].

The circuit diagram for the RF harvesting Air to electric interface is below:

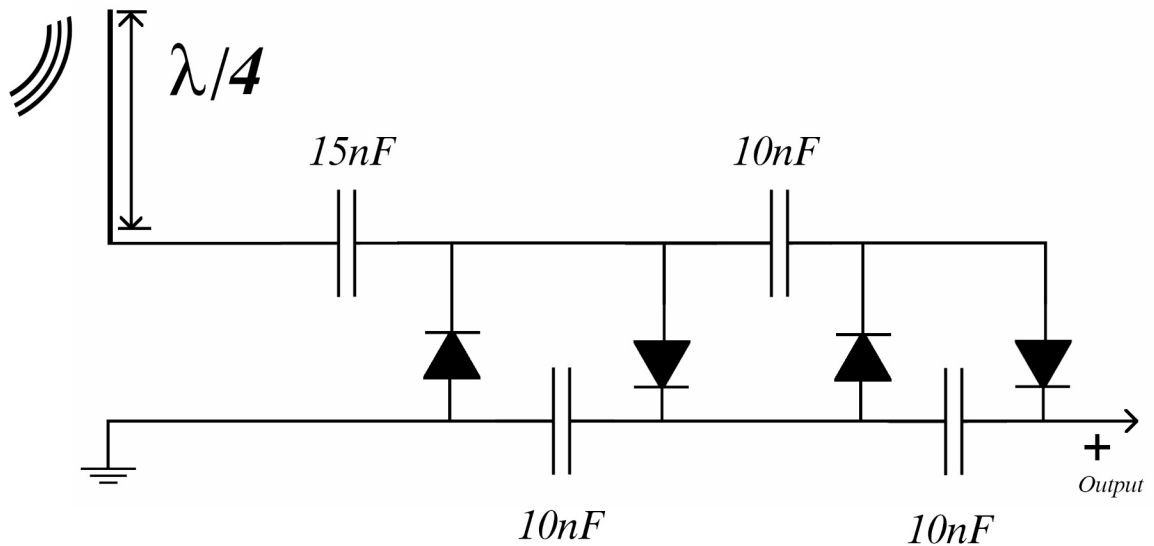

The active circuit (OA-1000 and above) does not need to use the RF spectrum as a power source, and instead uses the antenna only to detect signals in the EM spectrum. The antenna is instead used as a sensor, giving the oscillator circuit an input trigger signal to apply positive feedback. The active circuit needs only the series isolation capacitor to correct for the spare capacitance in the circuit, but still must impedance match the oscillator circuit to 50 ohms. The oscillator circuit has a zero theoretical resistance during the charging half of the oscillatory cycle, while infinite resistance during the discharging half. Due to the theoretical zero resistance, a 47 ohm resistor is included in the active circuit to come as close to the 50 ohm impedance match as possible. Matching the impedance of the antenna during the charging half of the oscillator cycle ensures the incoming EM energy from the antenna is rendered into usable current. Once input to the circuit, the EM wave triggers the oscillator to provide positive feedback against the incoming EM wave.

## **Part Selection and Manufacture**

We can now move on to the manufacture of key devices that enable the operation of the Orgone Amplifier circuit.

### **The Crystal Emitter**

The crystal emitter is the most important part of the Orgone Amplifier Circuit, and is unique to the Orgone Amplifier design. Any piezoelectric material can be used for the crystal oscillator so long the orientation of the crystal lattice is considered when terminating the electrical contacts. Some specimens produce a larger effect than others, with visibly clear mono-crystalline quartz being some of the most powerful specimens due to the strong natural order.

The visible clarity of mono-crystalline quartz allows for a power indicator light, which acts as a visual guide to the power entering the emitter. To couple the light most efficiently to the crystal, the light source can be epoxied directly to the lattice, or can be embedded by boring a hole into the specimen. Small specimens will usually need to use an epoxy mold, while large specimens can provide mechanical support for the light source. Below we will briefly discuss both methods.

#### Smaller Specimens

Clean the specimen of all dirt and loose material. Apply tape around the base to create a cup for the epoxy.



Add another layer of tape around the base so no resin leaks. Suspend upside down in a holder. Suspend the LED into the resin mixture until the epoxy sets.



#### Larger Specimens

Large specimens can support the light source and can withstand the stresses of boring a hole into the lattice. Quartz is very hard, diamond drill bits are required from 1-5mm diameter. Use water as a lubricant and create a jig to clamp the specimen. The LED can be epoxied into the bore hole after cleaned of drilling residue.



After the LED is included the contacts are terminated to the crystal in a similar manner.



## Crystal Cuts & Orientation

Careful consideration is put into the electrical terminations on the crystal, with attention paid to the geometry of the specimen used. The choice of facet selection when terminating the electrical contacts is described in [10]. Quartz based crystal oscillators have been used in electronics for timing devices, and we will use this research to describe the electrical terminations of a quartz specimen. A quartz crystal has a certain orientation as shown below:

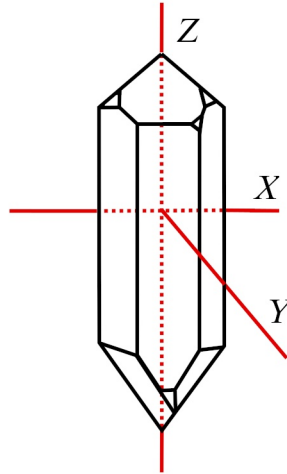

A quartz crystal will display 6 facets, and the convention is to orient the coordinate system so the largest facet is parallel to the X axis. We choose the largest and most parallel facets to terminate the electrical contacts, which is called the XY termination, as the cross sectional induced vibrations are on the XY plane.

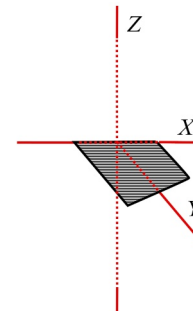

This is not the only termination possible, and other terminations display different resonance patterns in the crystal. For instance the most popular cut for clock oscillators is the AT cut, depicted to the right.

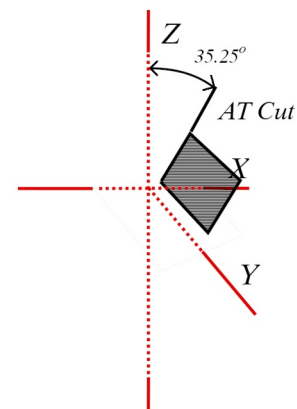

### Orienting a cut crystal

It is easy to orient the crystal lattice when there is a natural termination, but harder to do so for cut and polished pieces, as the crystal lattice can be oriented in many different ways before the polishing process. Some clues to the lattice orientation can be found on close inspection. Crystals usually fracture along the XY or AT planes, so it is possible to orient the crystal based on the visible imperfections. An example is given below:

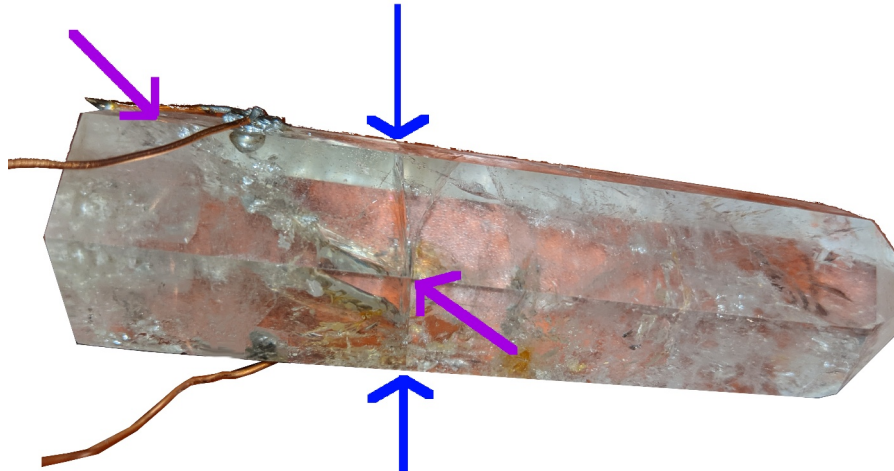

The blue arrows show the XY plane, and in purple arrows show the AT plane. Because the XY plane is slightly offset compared to the crystal orientation, we terminate the contacts with a slight offset to compensate.

Terminations to the quartz lattice can be performed in a few different methods, with the easiest being the conductive tape.



Quartz also has the ability to take a solder bead, but only when done correctly. The process is outlined in the below section.

### Soldering Contacts to a Crystal

The crystal must be cleaned with alcohol to remove any grease or oil films. Prepare the electrical lead by stripping insulation and tinning the copper conductor. Allow a large blob of solder to cool on the end of the electrical lead. The crystal must be heated evenly to prevent cracking. After the crystal surface is sufficiently hot, melt the large blob of solder onto the selected crystal facet. This

method usually creates a moderate bond, but it can be broken. A dab of epoxy is used to keep the wire and bead of solder in place. After the epoxy is hardened, the wire leads can be stripped and soldered to a circuit board.



Other methods of termination allow slightly more rugged devices. It is also possible to bore into the crystal as with the LED and fill the borehole with solder. This creates a very strong electrical and mechanical bond to the crystal, even when vibrating very intensely. A bore hole is drilled for each contact and filled with molten solder to create a strong mechanical bond. The strongest bonds are formed when the borehole is drilled in a way to create an inverted cone, so the widest portion of solder is within the crystal.

### **The Transformer**

The transformer used in the OA circuit can be purchased, salvaged from an old electronic device, or created with common electrical materials. The type of transformer used in this circuit can be found in old power supply units of computers and on the circuit boards of CRT televisions. Old power supplies were sometimes designed with a device called a power line choke. These devices help filter noise on the power line to condition the electrical signal for sensitive electronics. It is usually found on the high voltage side of the power supply. If salvaged parts are used from old electronics, ensure there is no energy in the device and unplugged from a power source. Below are some examples of transformers/power line chokes.

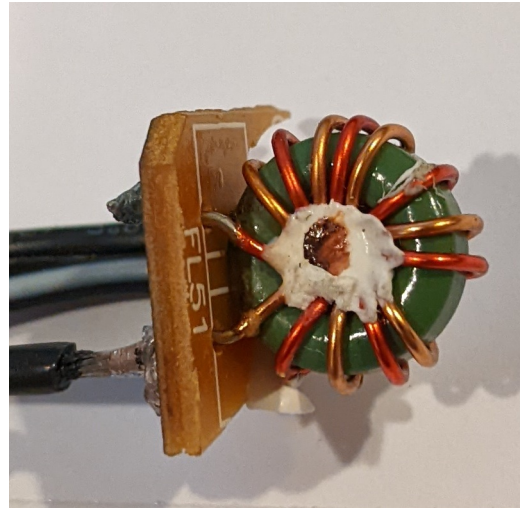

It is possible to salvage these parts by de-soldering the contacts to the circuit board and removing them. These actions are destructive to the old power supply, so make sure the sacrificial unit is no longer needed. A power line choke will have 4 terminals and ideally more than 20 turns for effective coupling. The right image is an example of a poorly suited device for the task as there are not enough windings for sufficient coupling. The left image shows the suggested part for the OA circuit.

If the recommended part is not available, or there are no salvageable parts, it is possible to construct a transformer by winding copper around a ferromagnetic ring, or even a steel nail.



To create a makeshift transformer, acquire suitable insulated wire. Some copper wire has a very clear and thin insulation made of enamel, and this is commonly referred to as magnet wire. This is the ideal wire for this application, but other wire might work such as the inner wires of cat5 cable. Thin wire with thin insulation is desired as to achieve the most possible turns around the magnetic material. A significant length of wire is needed to achieve the proper number of turns. One complete wrap around the ferromagnetic material is called a turn. If we design a device with 200 turns, and the magnetic material is 2.54cm circumference, 510cm of copper wire per coil is needed. The transformer has two coils, therefore 1020cm of wire is needed to construct this device. After constructing the makeshift transformer, we found the need to have well over 200 turns, and it was found that more wire was needed than calculated. As more wire is wound around the ferromagnetic material, the circumference increases, using more copper per winding. We account for this by adding 20% on to the total length.



To calculate the total needed length of wire, the following formula is used:

$$(\text{Number of turns}) \times (\text{circumference of material}) \times (2 \text{ coils}) * 1.2 = \text{Total amount of copper needed}$$

We take our total length of wire and arrange it into a giant U, with each leg measuring  $\frac{1}{2}$  the total length of the conductor. Label one leg of the U P1 and the other S1. At the bottom of the U, where both legs meet, on the P side add a label that says P2, and the S side a label that reads S2.

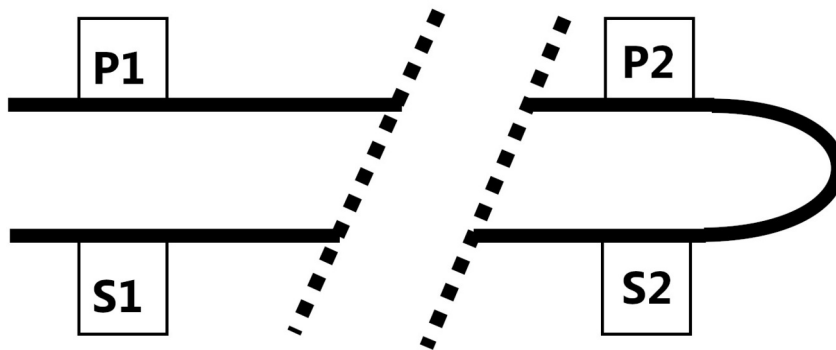
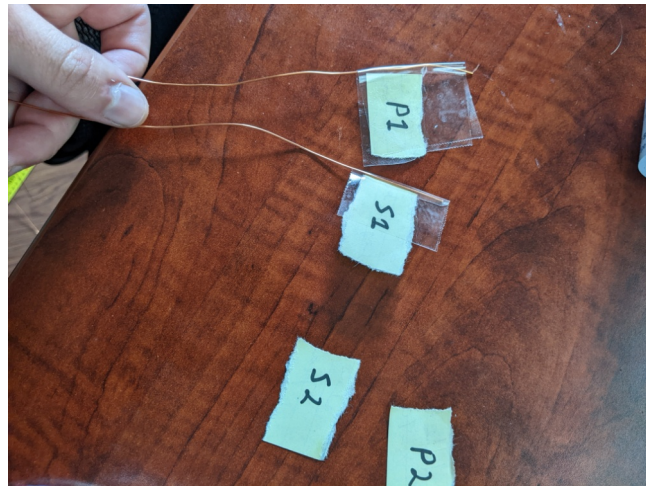
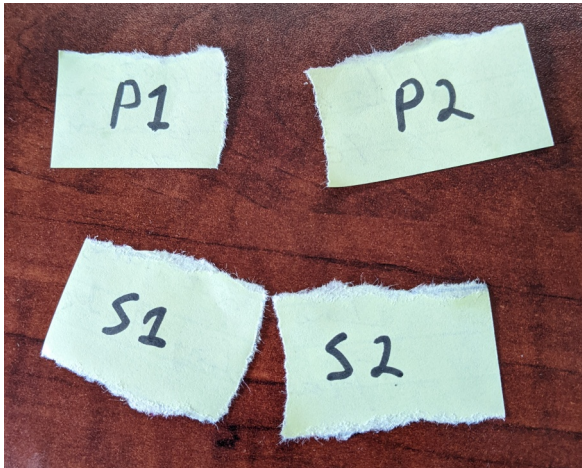

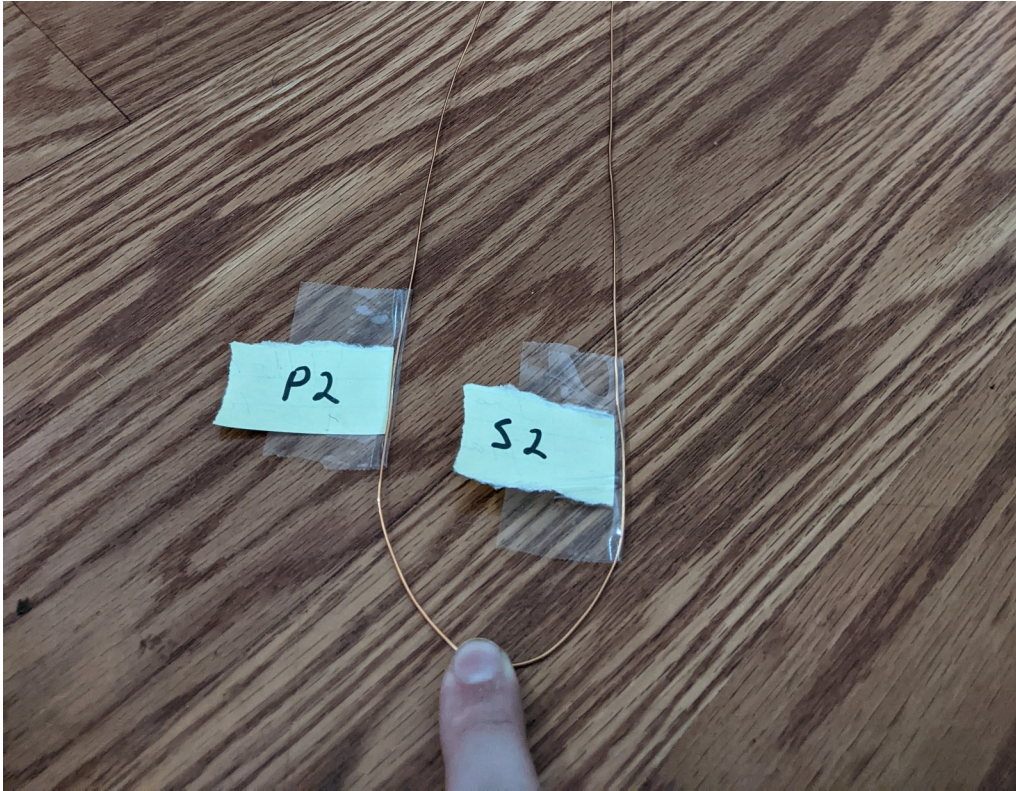

Take the bottom end of the U and wrap it once around the magnetic material, this is the first loop of the transformer called a turn.

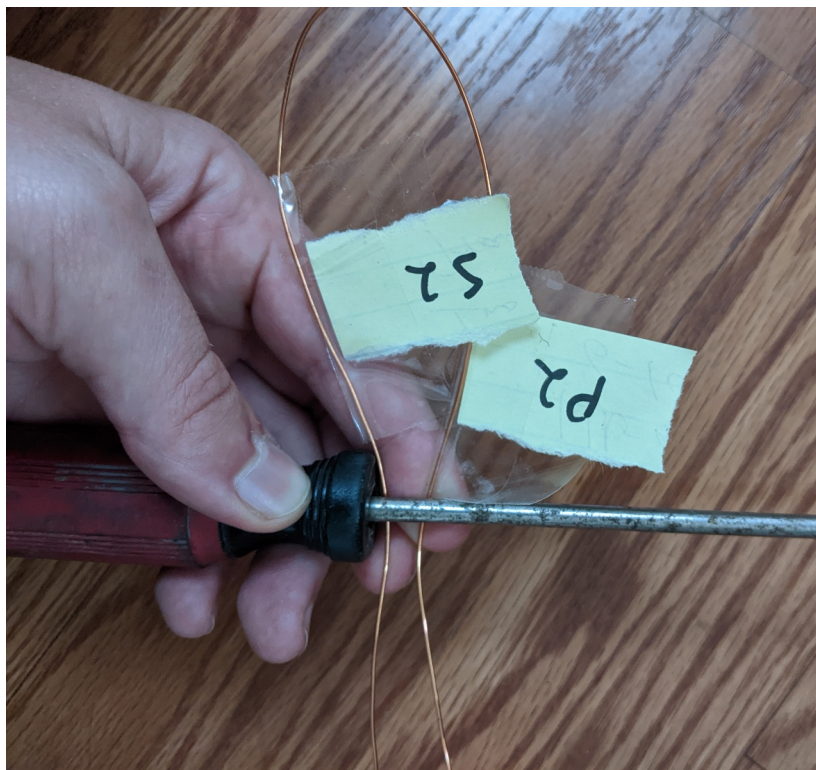



We want our transformer to have at least 200 turns, and possibly more if space allows. Wrap the loops around the magnet material and back. Doubling back over the first layer is beneficial to promoting coupling in the final component.

Once we have exhausted the length of the conductor, we wrap the whole bundle in tape, or dip in epoxy to keep the copper coils from unwinding. **The U can now be cut between the two labels**, and by separating the wires we have created a primary and secondary coil in the same polarity.

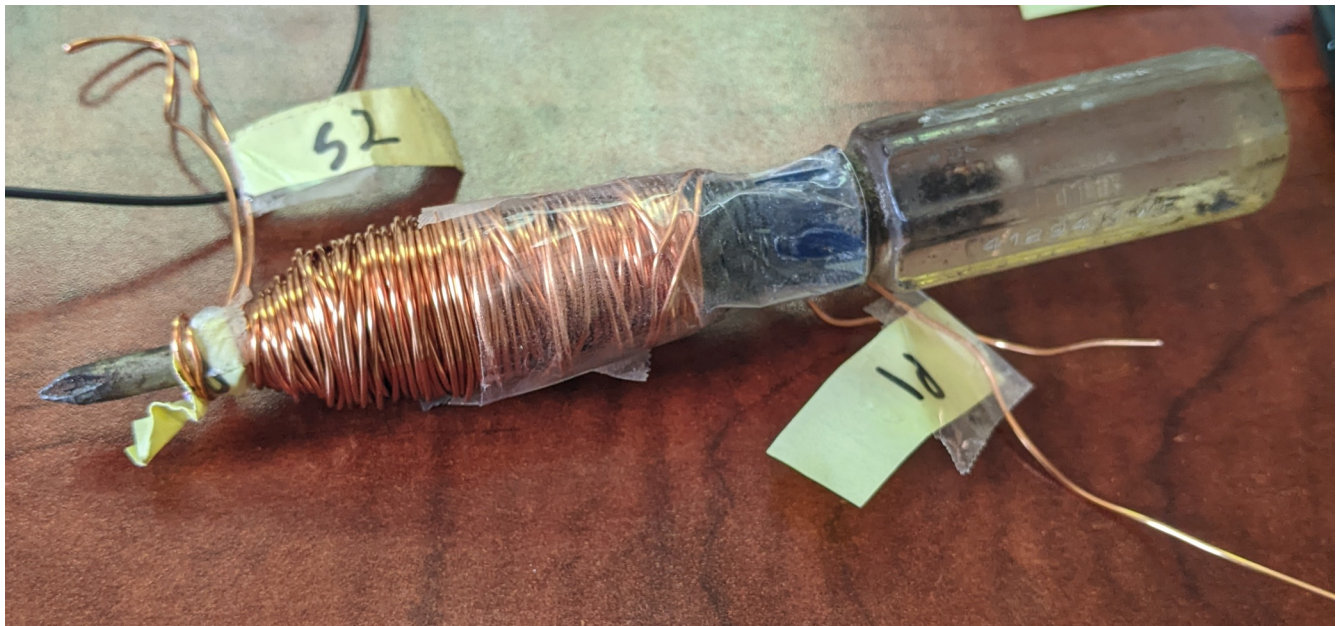

We ended up creating a device with well over 200 turns, and even though it was not ideal, it did function within a test circuit:

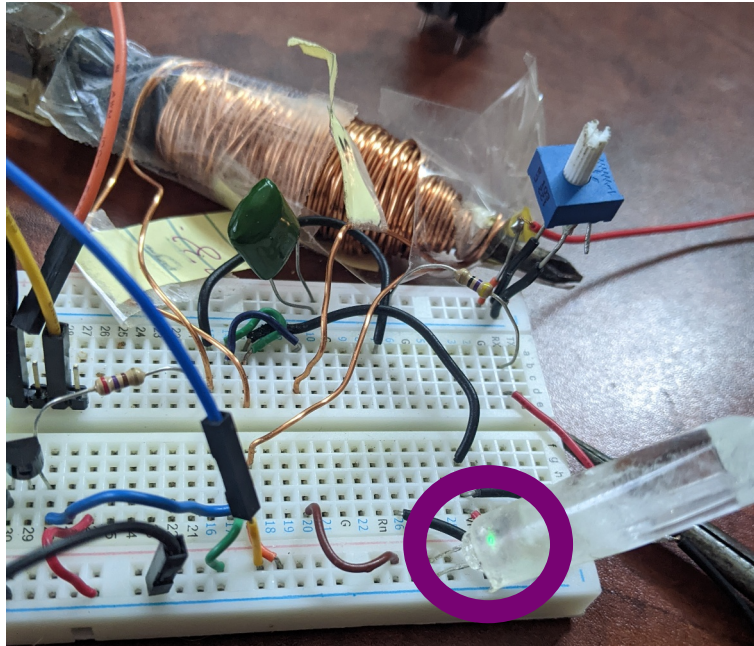

Transformer polarity test:

This is a test designed to show the polarity of a transformer.

Tools needed:

- Waveform generator (1 Volt pulse at 1 kHz)
  - can be achieved with a 555 timer
- two channel oscilloscope & leads
  - inexpensive two channel oscilloscopes available as single USB powered chip

We test our manufactured component by wiring it in the below fashion:

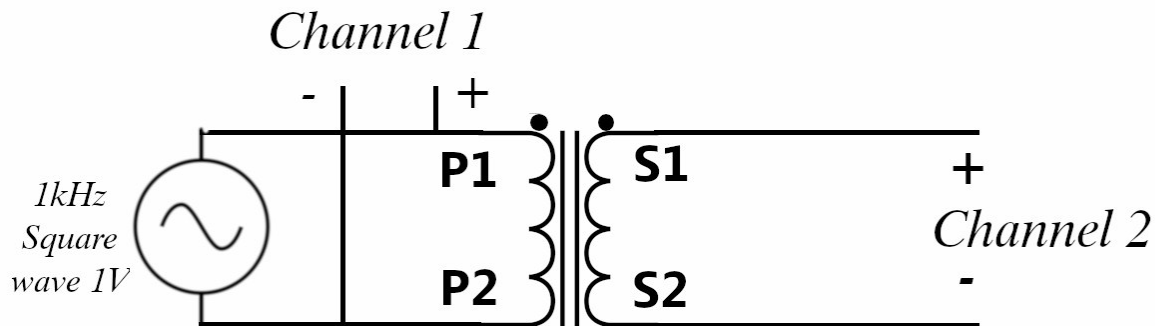



When we connect the two channel oscilloscope, we get the below wave forms. Channel 1 is shown in yellow while Channel 2 is shown in blue.

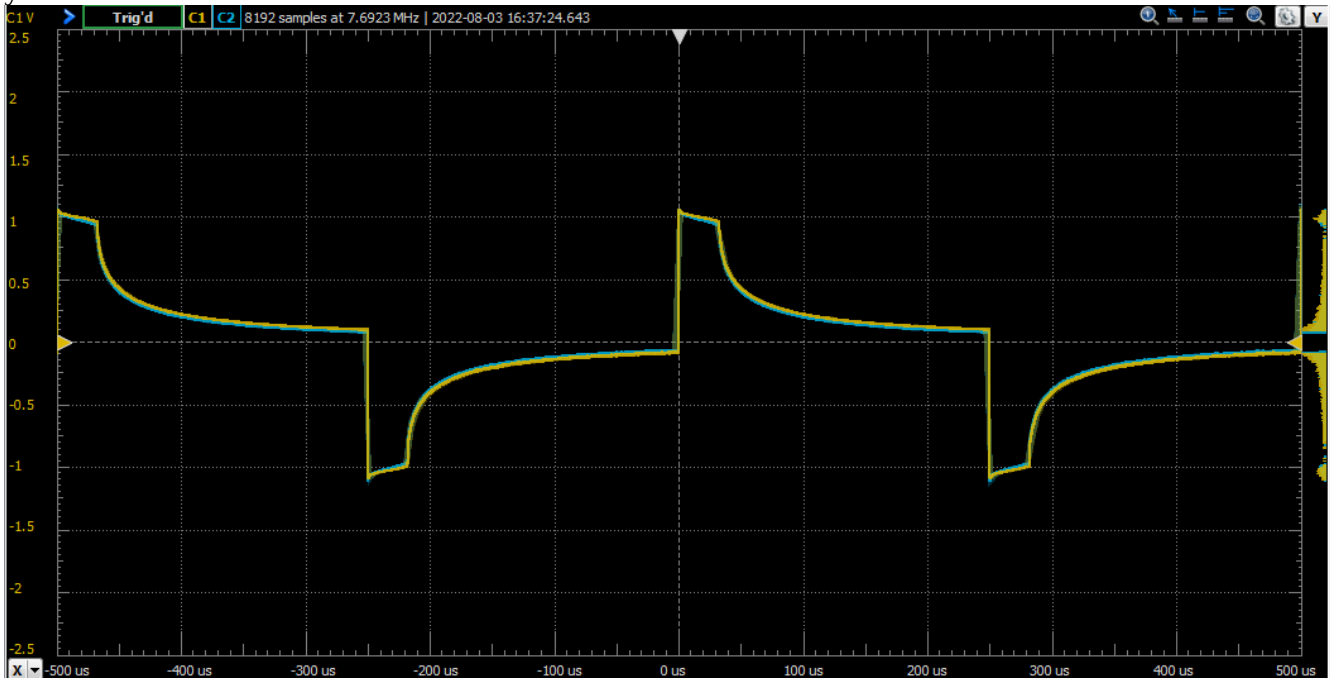

Notice both channel 1 and channel 2 are on top of each other, and are coupled. We want Channel 2 to be equal but opposite to channel 1, which would create an inverting transformer.

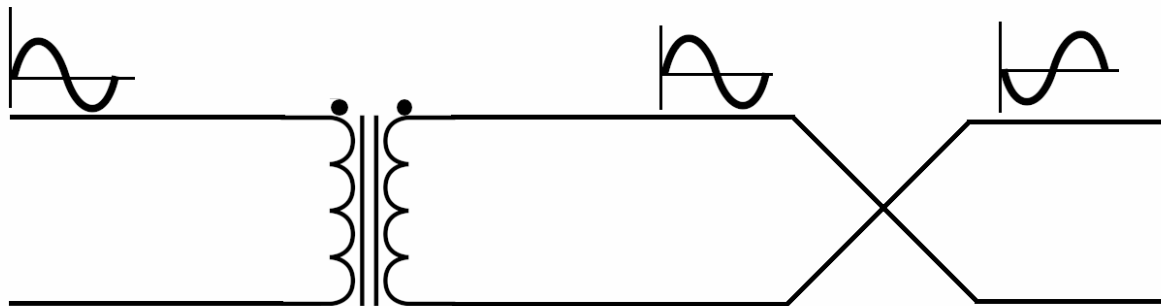

When the wires on the secondary winding of the transformer are reversed, the signal is equal but opposite the input signal, as seen in the below oscilloscope trace.

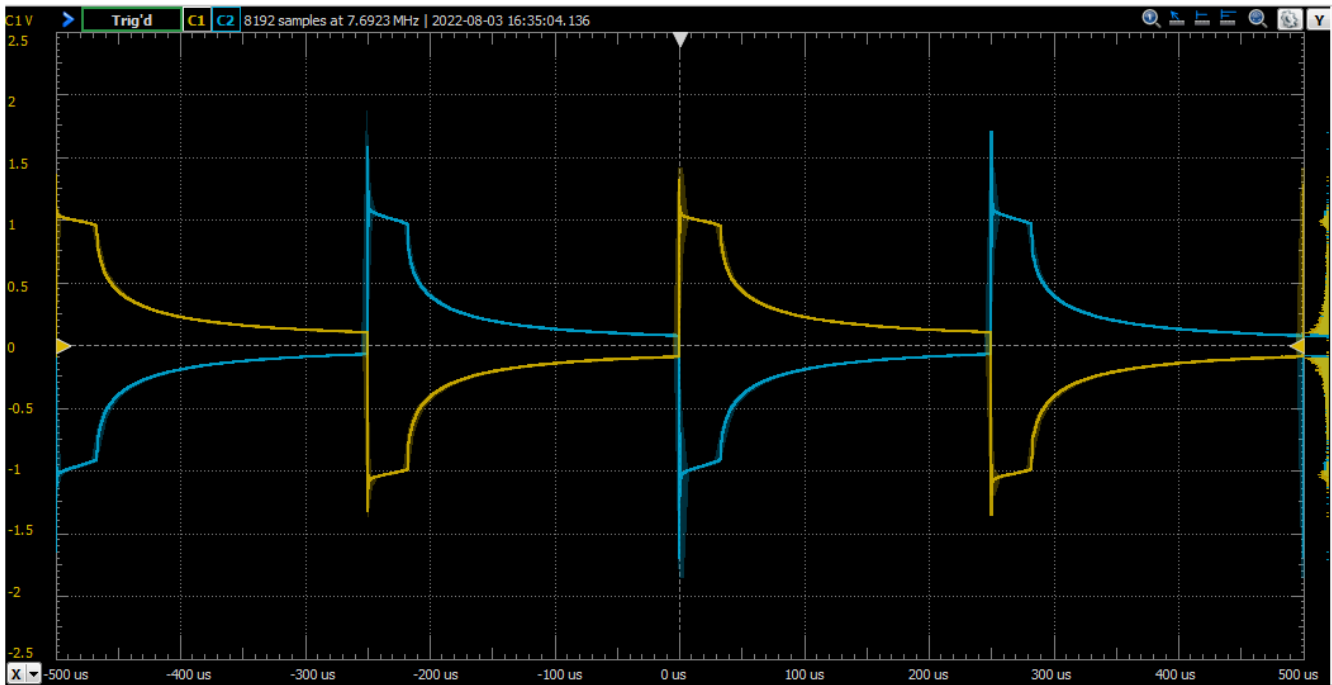

The above trace is the correct output for an inverting transformer and can be shorthand denoted with the below diagram. Notice the two dots are now on opposite sides, this denotes the polarity of the transformer.

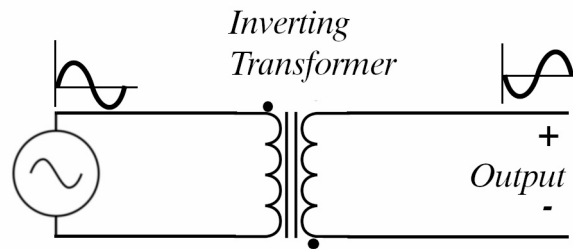

If we test a transformer and it produces an exact copy of the input signal, all we need to do is switch the wires on the secondary winding and the transformer will invert the incoming signal.

The transformer device we created is not ideal, it does not replicate the perfect 1V square wave supplied to the input. Thinner wire, significantly more turns, and better ferromagnetic material would create a more effective device.

### **Transistor and other components**

At the simplest, the circuit can be made with just the crystal, transformer, transistor and a power source. Even a battery that other electronics would consider out of power would work for this circuit. Most electronics will run an alkaline cell to 1.2V, while this circuit can operate down to 500mV on silicon and as low as 25mV on germanium.

A transistor is almost impossible to create without the special equipment available to component manufacturers, so we recommend ordering the 2n3904 or equivalent. Harvesting a transistor from old electronics is possible, and it is also possible to create and use tube electronics, but tubes are so uncommon it would be more likely to find a suitable semiconductor device. NPN transistors, capacitors, diodes and resistors can be found in old power supplies. Magnet wire can be found in microwaves, CRT televisions, and electric motors. When tearing apart old electronics, **first and foremost is safety**, make sure the reader understands what safe disassembly looks like for each device. Power must be off and capacitors discharged. Make sure to understand each component if intended to use in the Orgone Amplifier circuit. Some components might look similar but internally they carry much different functions, or might have similar operation but might have specific properties that make them not ideal for use. Without access to recommended parts, this might be a bit of a trial and error process, but it is still possible to create an operating circuit. You can confirm the suitability by looking closely for any writing on the part, enter the part number into a search engine and view the datasheet. Compare the datasheets to the suggested parts and its possible to determine the suitability to the circuit. As an example, we found this semiconductor device at the bottom of a parts bin.

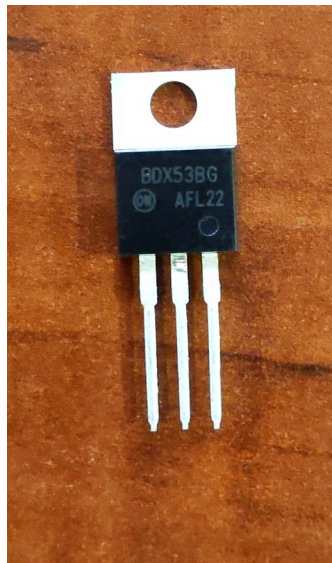

We can see that it has a part number of BDX53BG. When we enter this part number into a search engine, we can find the datasheet. On looking at the datasheet we notice that it is a Darlington pair transistor with an excellent gain. When we inserted this part in a development circuit, it performed very well. It is possible to make effective triode vacuum tubes with only a glass blowing torch, an incandescent light bulb and a low level vacuum source. Doing so is dangerous and requires significant power for the tungsten filament, so we only mention triode use as a possibility but not as a very feasible option. Below is a diagram of the OA circuits and the recommended parts list.

## Parts List:

### OA-100 RF Harvesting circuit parts list + diagram

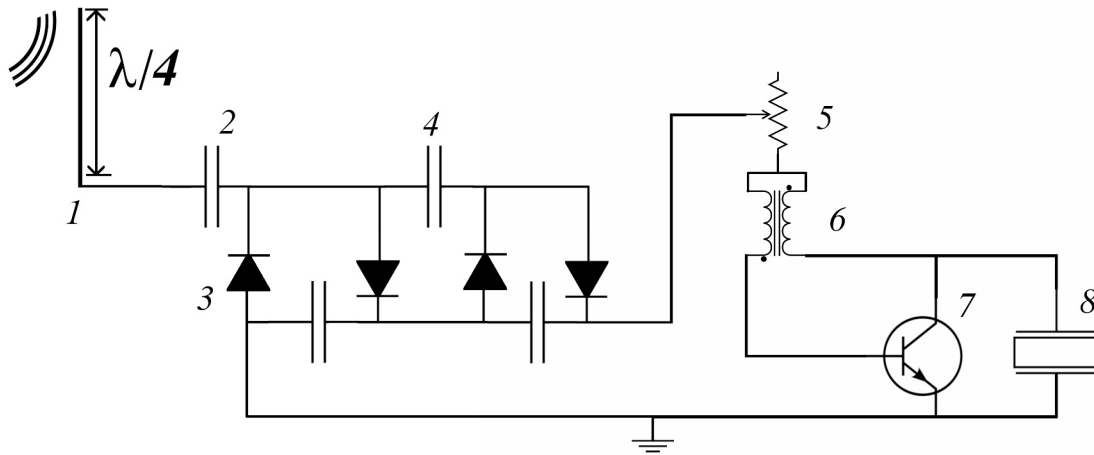

Number	Description	Part Number
1	¼ wave Antenna	B09J8N8TXW, B07XFZB62D, B078H4F8R6
2	Matching Capacitor	Calculated 12.5nF
3	Schottkey Diode	1N4148TR
4	10nF Capacitor	-
5	10kOhm Potentiometer	-
6	Transformer	BoJack EL-14 600:600
7	Germanium NPN transistor	ac127
8	Crystal Oscillator	Fabricated

**OA-1000 Powered amplifier parts list + diagram**

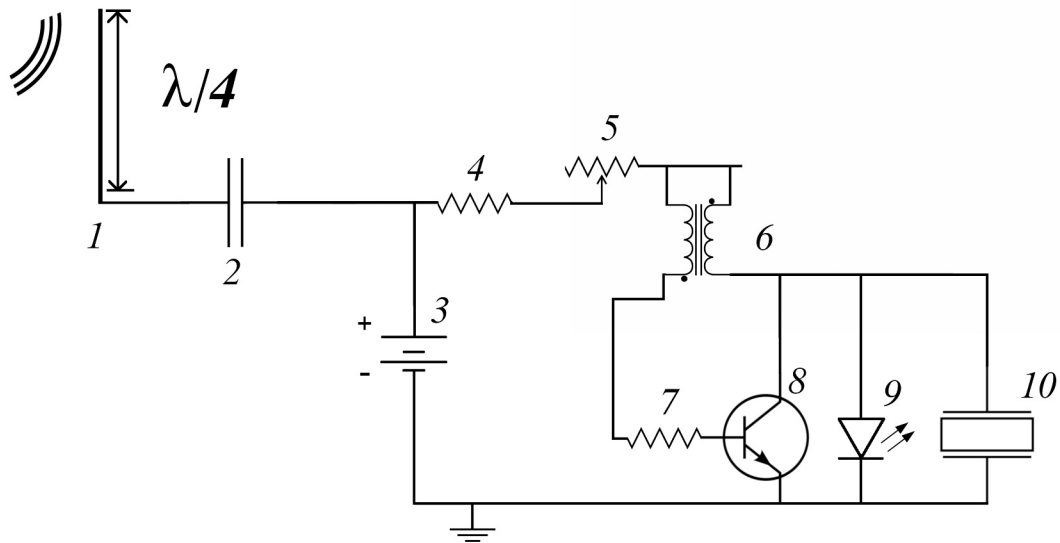

Number	Description	Part Number
1	¼ wave Antenna	B09J8N8TXW, B078H4F8R6
2	Matching Capacitor	2.5nF
3	1.5V AA battery	-
4	47 Ohm Resistor	-
5	10kOhm Potentiometer	-
6	Transformer	EH24-1.5-02-4M5
7	30k Ohm Resistor	-
8	NPN transistor	2N3904
9	LED Indicator	3.2V 20mA
10	Crystal Oscillator	Fabricated

Optional: For frequency control, include a 10kohm or greater potentiometer in series with #7 30kohm resistor. For Multi-band antenna arrays, connect additional antennas each with individual matching capacitor.

## **Build Steps (active unit)**

### **Step 1)**

Get all parts and tools together.

We recommend first time builders start with the OA-1000 active unit.

Tools that may be needed:

- Battery holder (Easier to connect to battery)
- Development Circuit Board
- Wire (Magnet wire or breadboard wires, 20 gauge and 22 gauge fits in the breadboard)
- Wire stripper (May be needed depending on what wire you have)
- Soldering Iron (Needed if you will be making a final build)
- Solder (needed to tin the tips of the magnetic wire)
- 8mm or 5/16ths wrench (Antenna connection, might need both)
- 11mm wrench (potentiometers)
- Drill (used to create the holes in the final device)
- 5/16" drill bit (potentiometer hole)
- 17/64" drill bit (antenna adapter hole)

### **Step 2)**

Get all pinouts of parts

#### Transistor

2n3904

TO-92 Package

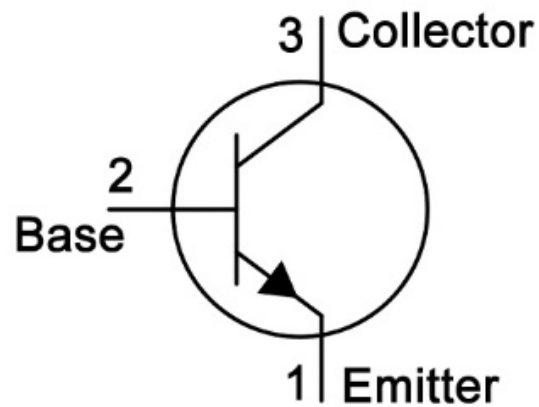
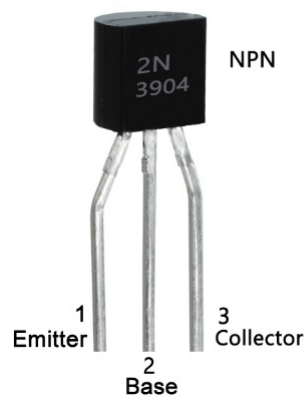

The orientation of the device can be determined by looking for the flat side, which is the front face of the device.

## Transformer

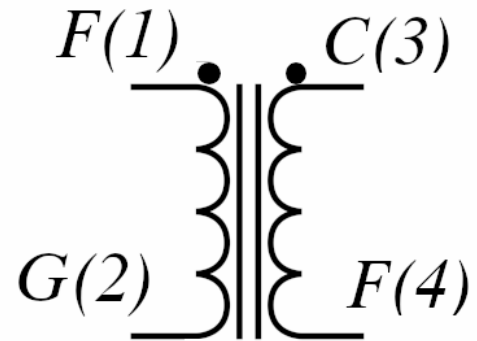
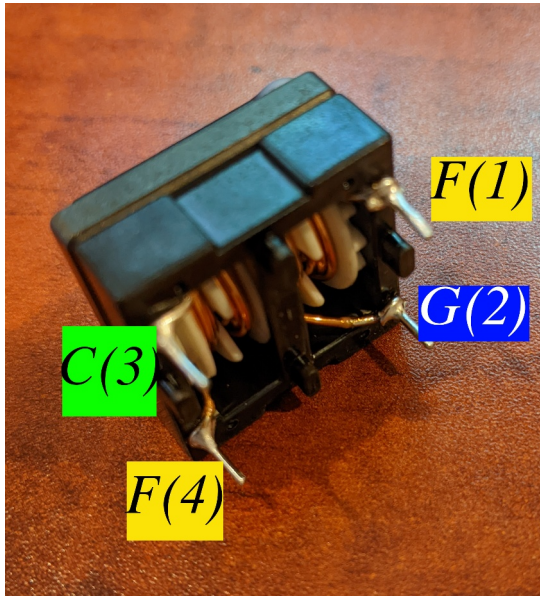

Remember the transformer must be wired as an inverted transformer. The recommended part is not inverting, as shown by the two dots at the top. We can wire this transformer as inverting, by connecting pin 4 with pin 1, which is why they are both labeled “F.” We will use this convention later when building the circuit. To check if the transformer is wired in inverting/non-inverting, refer to the transformer polarity test as described in the section dedicated to building a transformer. If building your own transformer as detailed in the transformer section, P1 and S2 are terminals F(1) and F(4), while P2 is G(2) and S1 is C(3).

## Potentiometer



If the potentiometer is turned counter clockwise, resistance is maximum between pins 2 and 3. the opposite is true if the knob is turned to the maximum clockwise position. We use pins 2 and 3 for

the intensity dial, and if a frequency dial is included, pins 1 and 2 are used. Connect the unused pin to terminal 2 to allow for a constant connection.

**Step 3)**

Get development board

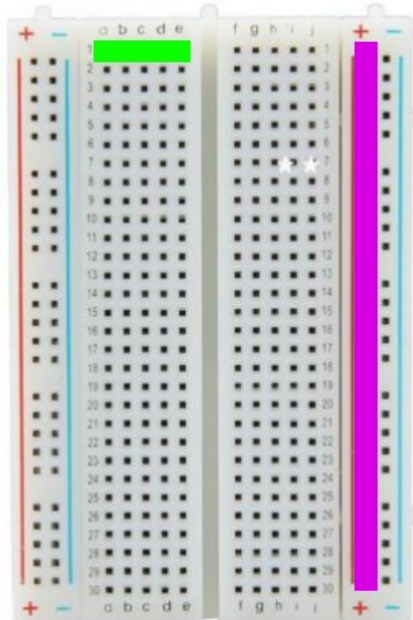

A development circuit board or breadboard is a prototype tool that allows for quick replacement of parts. The board has two power rails, one for each side of the board. All dots on the power rails are connected, denoted in magenta. Each row of 5 dots is connected, denoted by light green. Each power rail and row in the breadboard is a “node” which will share voltage across all connections in that row.

**Step 4)**

View circuit assembly diagram and circuit pictures

Each node is labeled with a color and letter.

Two pictures are given of the real circuit with corresponding node labels.

*To Antenna*

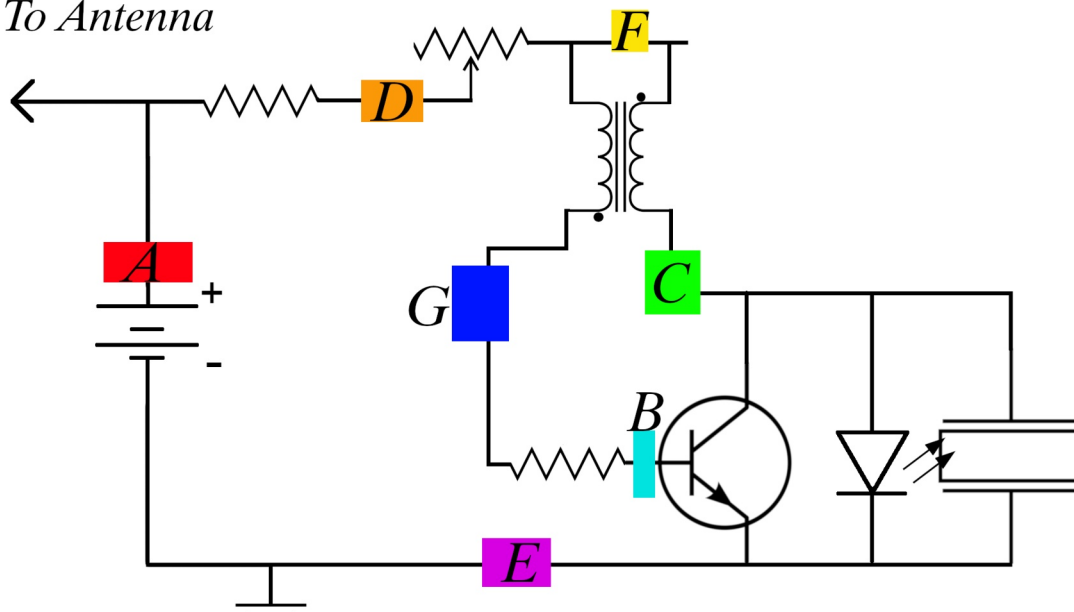



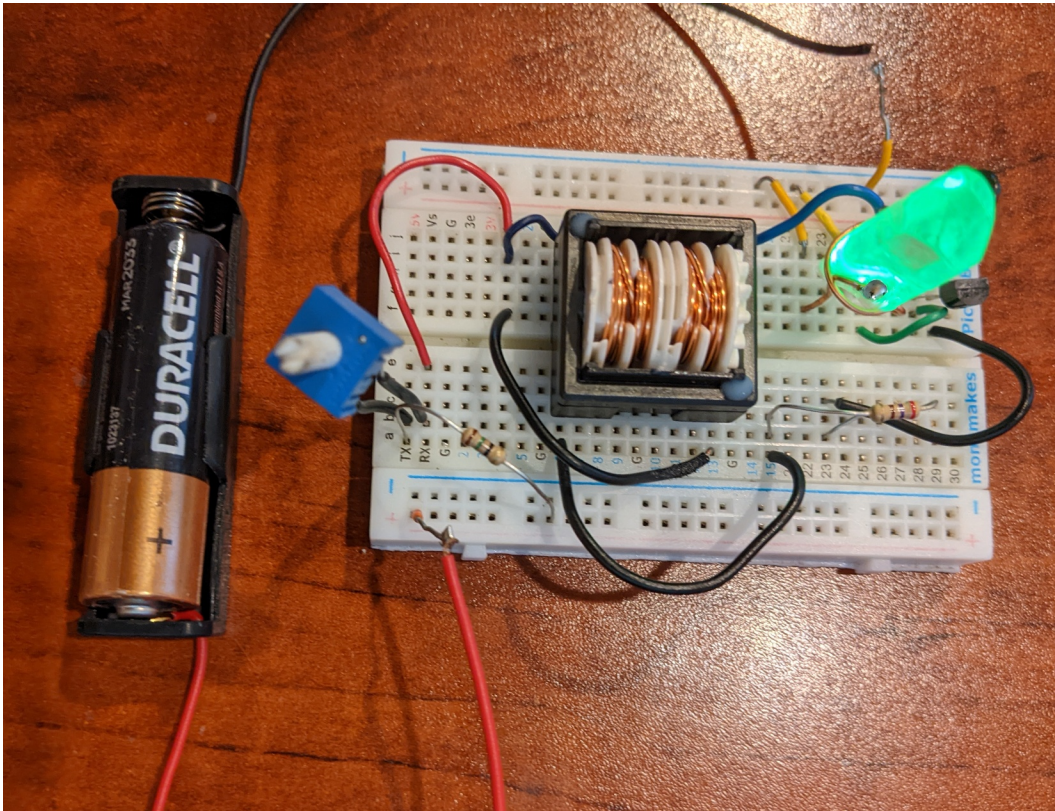
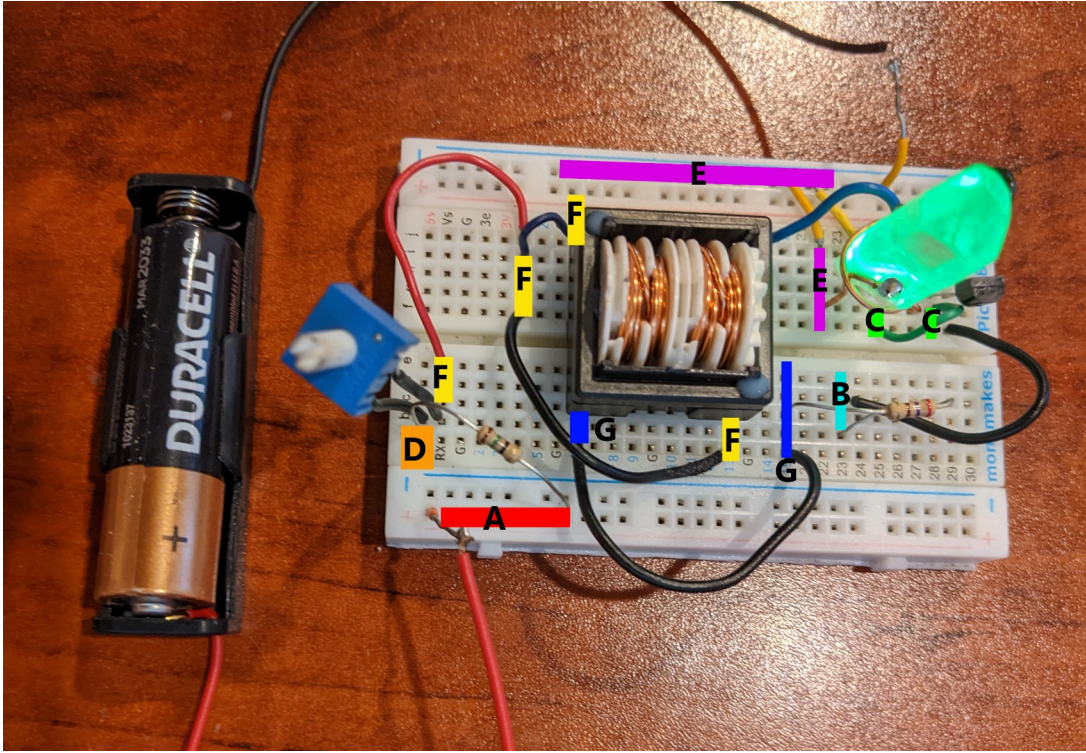



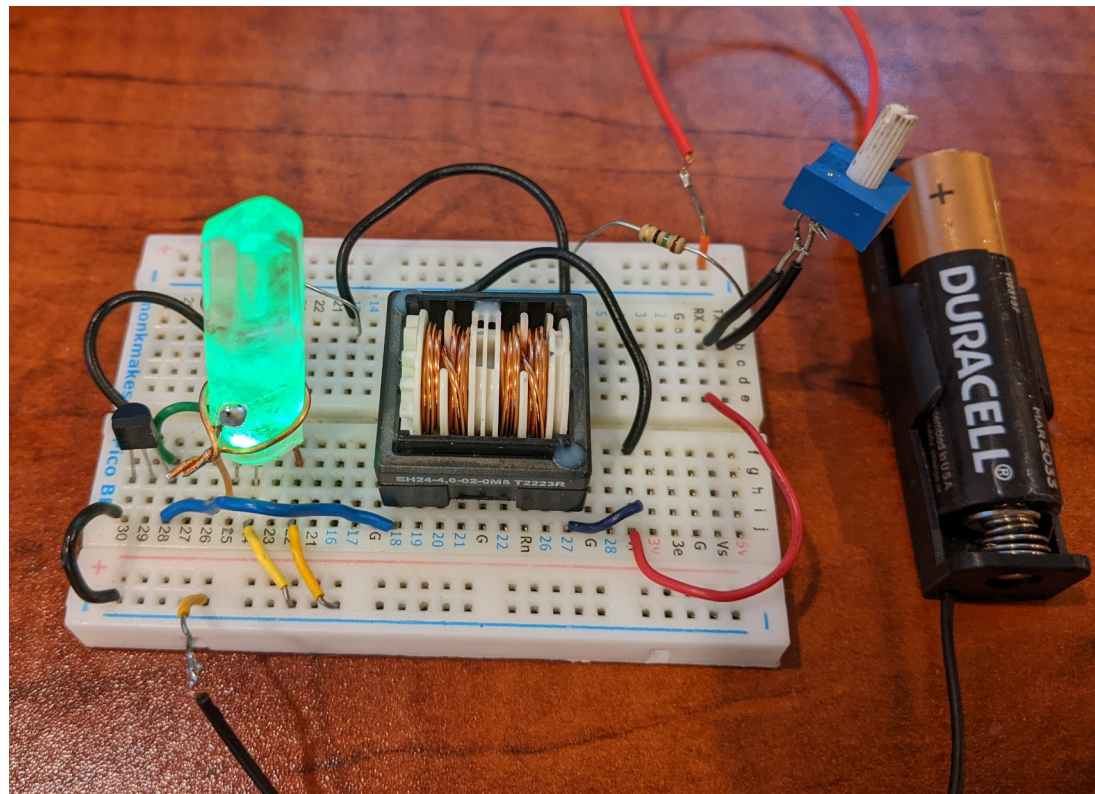
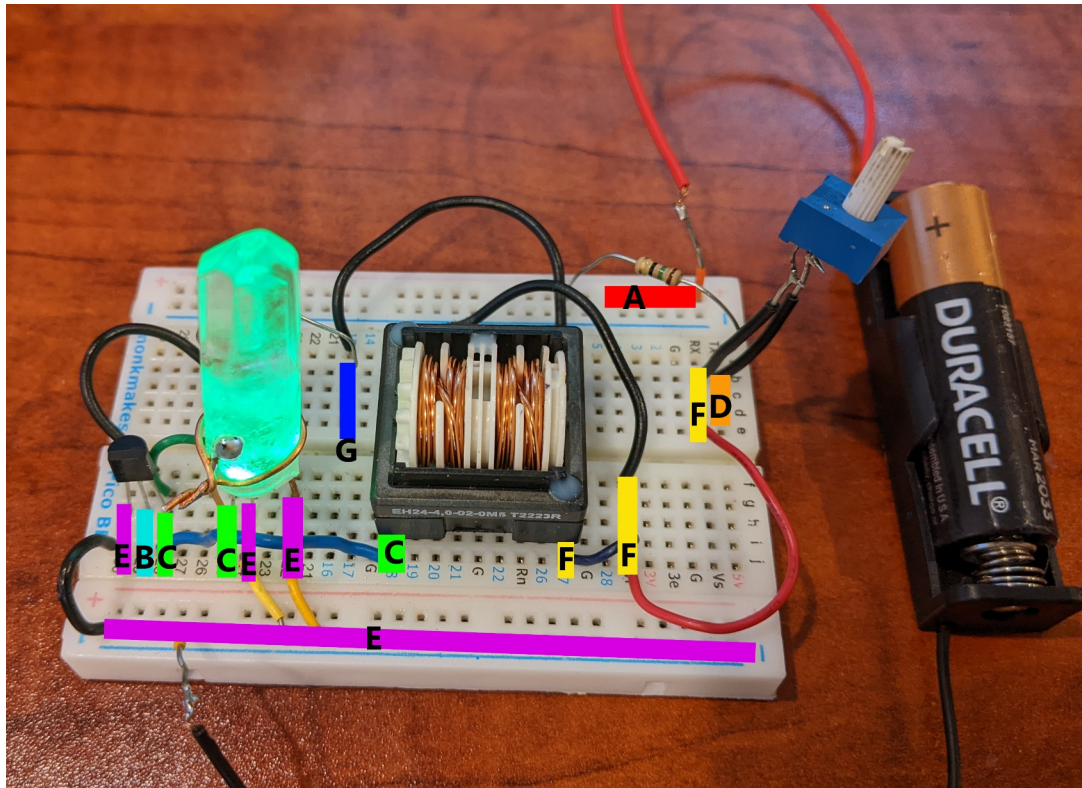

**Step 5)**

Insert transistor in breadboard as shown in diagrams. When looking at the flat face of the transistor, the leftmost pin gets connected to ground.

**Step 6)**

Insert transformer in reverse polarity as shown in diagrams. If unsure the transformer is in reverse polarity, refer to the transformer polarity test section to determine polarity.

**Step 7)**

Connect crystal emitter

Either terminal of the crystal can be connected to node “C” as long as the other is connected to node “E”

**Step 8)**

Connect LED

LEDs have a polarity, and must be connected in a certain way to emit light. The LED is a diode, so it has an anode and a cathode, denoted by the length of the terminals on the unit. The anode is always longer and must be connected to Node “C” in the circuit. The Cathode gets connected to ground, which is node “E” in the circuit. For optimum LED performance, connect 660uH inductor in series with LED.

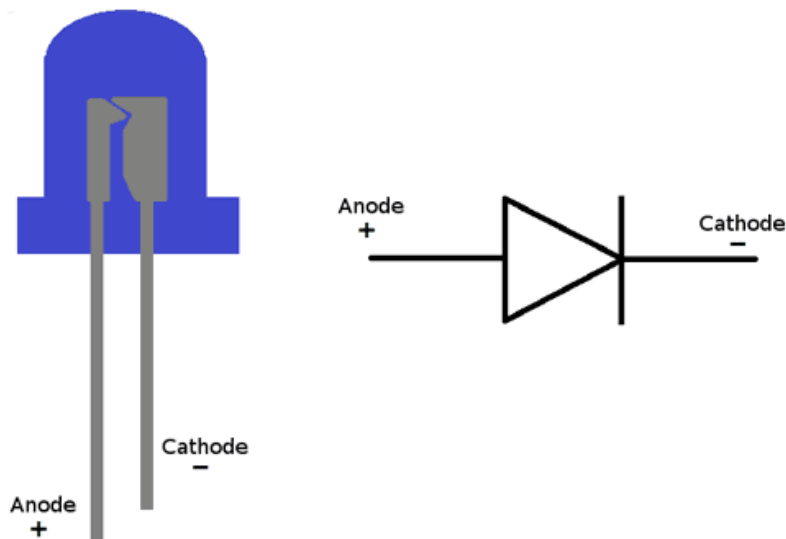

**Step 9)**

Connect 30kohm resistor

Optional: To create a device where frequency is controlled, add in a 10k ohm potentiometer or greater in series with a 30k ohm resistor using pins 1 and 2 of the potentiometer. Connect the unused pin 3 to pin 2 with a small wire.

**Step 10)**

Connect 10kohm intensity potentiometer using pins 2 and 3. Connect the unused pin 1 to pin 2 with a small wire.

### **Step 11)**

Connect power source to circuit

### **Step 12)**

Test oscillations with an oscilloscope. **At this point the circuit should function** and the LED should illuminate. The circuit will oscillate with the resonant frequency of the crystal without any feedback from the EM spectrum. If the LED does not illuminate or the circuit does not oscillate, start the troubleshooting steps in the dedicated section.

### **Step13)**

Create impedance matching circuit as detailed in the dedicated section.

### **Step 14)**

Connect antenna + impedance matching circuitry to circuit. Antenna has an input pin. Solder or crimp wire to active pin and solder ground connection to body of connector. It is also possible to use RG316 RF cable to terminate the antenna.

### **Step 15)**

Final integration and build. Solder components onto a circuit board for a more robust circuit. Drill holes in an electronics project case for the antenna(s) and potentiometer(s). Install circuit board with standoffs and affix to case with adhesive. Re-test circuit after integrated in case.

### **Step 16)**

Done!

## **Designing a New Circuit**

OA-1000 circuits run from a 1.5V alkaline cell, but it is possible to run the circuit on higher voltages. We will now demonstrate the design of a new circuit that runs on two AA batteries in series with a 3V input voltage.

The LED turn on voltage is somewhere between 2.2 and 3.2V, we will use 3.2V. The LED voltage drop should be 1.5x to 3x the source voltage, so for a source of 3V, we can run anywhere from 2-3 LEDs in series. 2-3 LEDs in series requires a pulse of 6-9V from the oscillator, which is below the 50V rating of the transistor, so we can use the same 2N3904 used in the 1.5V circuit. The 1.5V circuit needed a 30k ohm resistor for optimum oscillations based on the internal function of the 2N3904. To find the value of our new base resistor, we will use a technique called Kirchhoff's Voltage Law, as described in the below image.

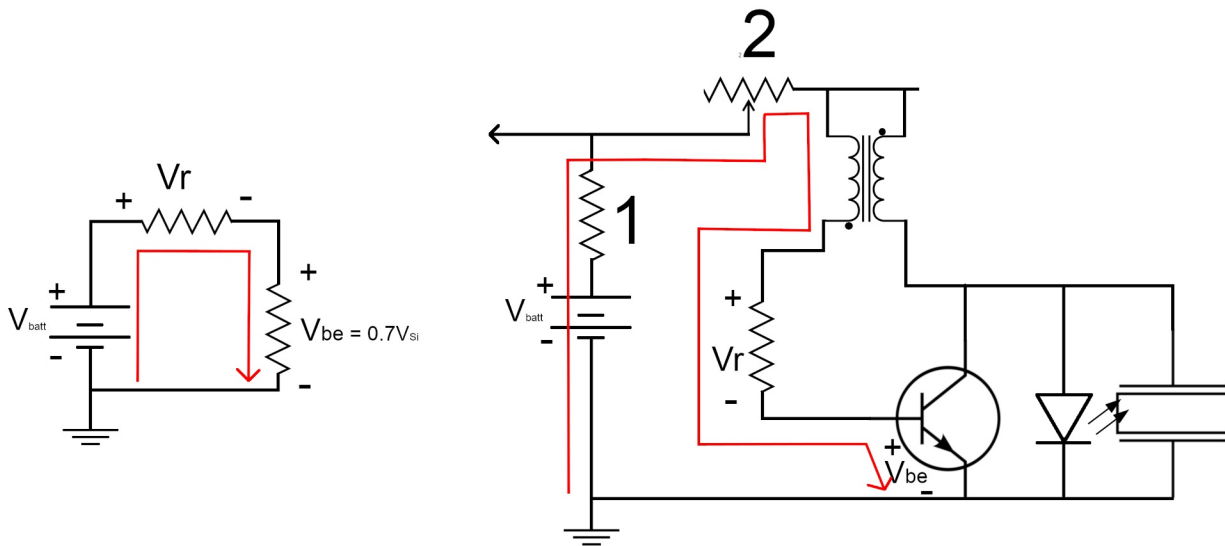

The KVL path is shown above. The voltages involved in the KVL analysis is the voltage of the battery, **V<sub>batt</sub>**, voltage drop of the 30k ohm resistor, **V<sub>r</sub>**, and voltage across the base emitter of the transistor, **V<sub>be</sub>**. The right diagram shows the KVL path through the OA circuit, and the left diagram is the simplified version of the same KVL path. The first simplification is the voltage source resistance is ignored, as it is small compared to the 30k resistor. The second simplification is the intensity potentiometer is set to maximum, displaying a zero resistance. The third simplification allows us to remove the transformer, as the transformer lets DC currents pass so it can be ignored in our equation. Kirchhoff's Voltage law states that the battery voltage, **V<sub>batt</sub>**, **must be completely dissipated** in the circuit components along the KVL path. Tracing around the circuit we now have a KVL equation that states **V<sub>batt</sub> must equal V<sub>r</sub> + V<sub>be</sub>**. More information about the KVL technique can be found in [11].

Our derived KVL equation:

$$V_{batt} = V_r + V_{be}.$$

If we solve for V<sub>r</sub>, the voltage drop across the base resistor, we get the below equation:

$$V_{batt} - V_{be} = V_r$$

if V<sub>batt</sub> = 1.5 and V<sub>be</sub> = 0.7 (as the case for the 2n3904 transistor), our formula takes the below values:

$$1.5V - 0.7V = 0.8 \text{ volts. Therefore the voltage across } V_r \text{ is } 0.8 \text{ Volts.}$$

Using ohms law,  $0.8V / 30,000 \text{ ohms} = 26\mu A$ . This is the current through resistor V<sub>be</sub> and into the base of the transistor at the maximum.

Using the calculated current, we can take this to our new circuit which has a V<sub>batt</sub> voltage of 3V.

$V_{batt}=3V, V_{be} = 0.7V$

$3V - 0.7V = 2.3V$

$2.3V / 0.000026 \text{ amps} = 88k \text{ ohm resistor.}$

For a source voltage of 3 Volts we use a roughly 90kOhm resistor instead of the 30kohms used in the 1.5 volt circuit. For frequency control, use a 30kOhm resistor and a 100kOhm potentiometer in series instead of the 90k resistor. Our new circuit will look like the below diagram:

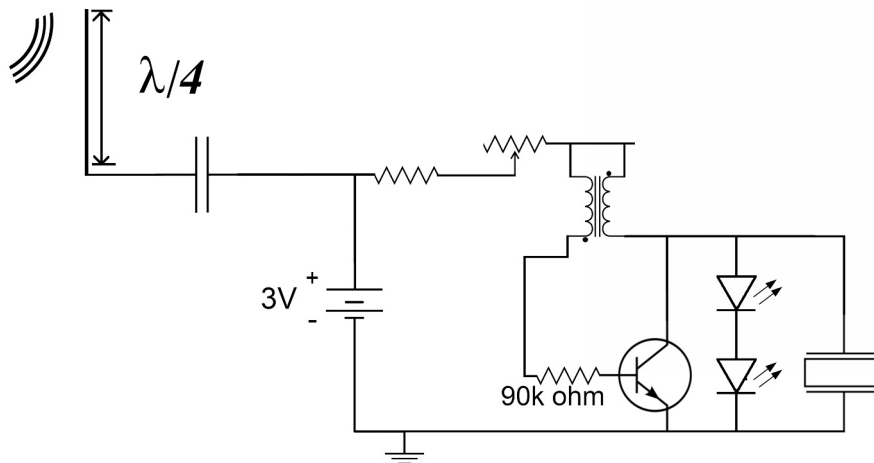

## Troubleshooting

Tools: Oscilloscope, volt meter, test leads

Problem: My LED is not illuminating/I cant tell if my circuit is working

- 1) Probe the power source, make sure power is going to the circuit by testing voltage between node A and node E. Voltage between node A & E should be very close to the power supply voltage.
- 2) Turn intensity potentiometer to max. Probe node D and node E. Node D should have the same voltage as the power source. If there is no voltage, there is no connection between node D and the positive terminal of the battery, or no connection from node E to the negative terminal of the battery.
- 3) Probe voltage across nodes C and E on the transistor. If it is the same voltage as your source, the transistor is 'off'. If the voltage across C and E is at or below 0.7 volts, the transistor is stuck "on."
- 4) If there is a square wave across transistor terminals CE the circuit is working correctly. If the oscilloscope displays a signal similar to the below image for the voltage across the collector (node C) and emitter (node E) of the transistor, the circuit is working correctly.

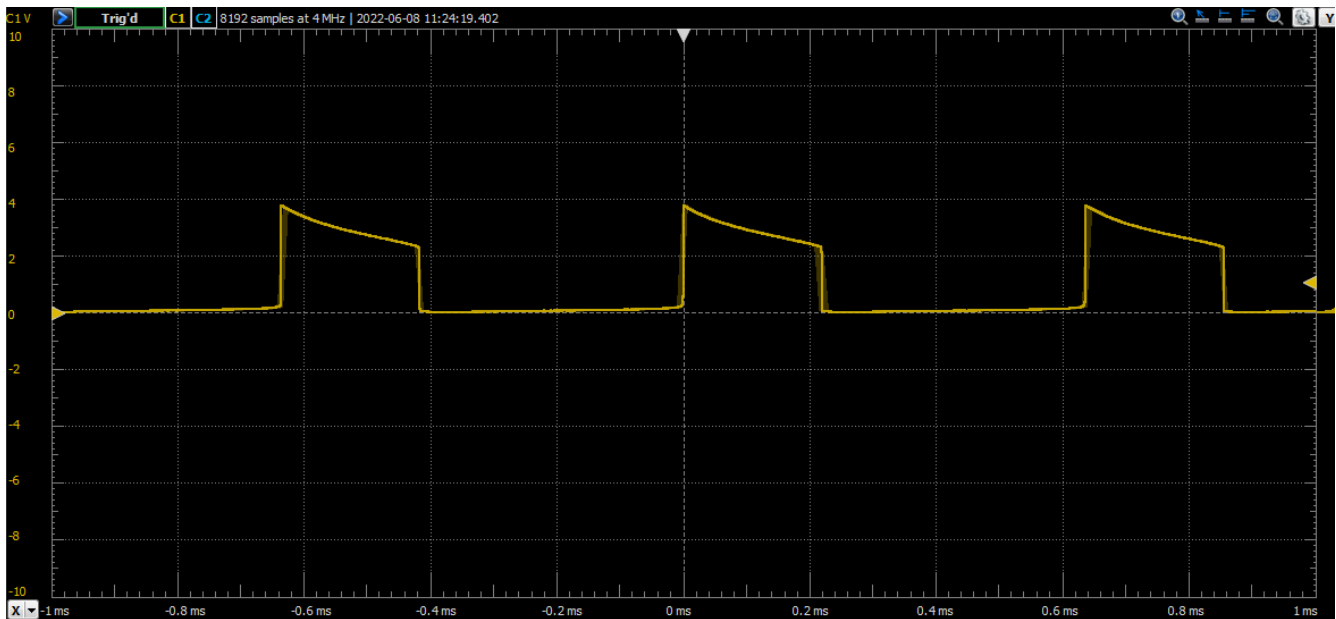

If this signal is present across the crystal and the LED is not illuminated, check LED for connection and correct polarity.

#### **Case 1:**

transistor stuck “off”

cause: voltage across terminals B & E of the transistor is less than 0.5V, transistor will not turn on

correction: check connections, check if battery is dead, make sure base resistance is not too high

#### **Case 2:**

transistor is stuck “on”

cause: voltage across terminals B & E of the transistor is too high, transistor stays “on”  
correction: check polarity of transformer, or increase base resistance (terminal B) of

transistor

#### **Case 3:**

transistor is “on” and I have the correct resistor, battery is not dead but the circuit is still not oscillating

cause: transformer is not inverting, or connections are incorrect

correction: test that the transformer is wired correctly by following transformer polarity test. Re insert the transformer into the circuit with correct polarity and re-test.

#### **Case 4:**

Symptoms: I don’t know what’s going on. I am pulling my hair out trying to figure out this circuit.

Cause: Frustration can often make problems not clear and sometimes this obscures the problem. Check all connections by testing for continuity, make sure you are using the right parts in the right way (check pinouts). If a multi meter is available, you can turn off the circuit and check for continuity from



the base of the transistor (node B) to the power rail (node A), and the same from the collector of the transistor (node C) to the power rail (node A). make sure the emitter of the transistor is connected to ground (node E) which is also connected to the negative of the battery. If the LED is wired correctly, and there is battery voltage across both the base and the collector of the transistor, it should begin to oscillate.

Note: Due to the extensive detail and troubleshooting tips offered in this document, the OA project will not diagnose, troubleshoot or examine circuits built by readers.

## **Advantages of the Orgone Amplifier Circuit and Defense of the Novelty**

The following section is devoted to addressing distinguishing features of the Orgone Amplifier and defend the originality of the design. Each point touched on has a devoted paragraph briefly explaining the distinguished feature.

### **Temperature and Pressure Resistance**

Like organite, the goal of the orgone amplifier is to produce orgone at a very wide range of environmental conditions. By creating a circuit with very few components, the Orgone Amplifier circuit is resistant to very cold and very hot temperatures, and also very rapid temperature changes. The OA circuit does not have any components that are pressure sensitive, which allows operation at sea level and extreme altitude. This allows the user to bring the orgone amplifiers to very remote and harsh environments.

### **Operator Defined Intensity and Frequency**

Unlike organite, the Orgone Amplifier circuit has the ability to adjust the intensity of the emission produced by the device. This ability allows the user to control the range of the effect, from just a few meters up to the maximum designed range of the unit. Unlike Organite, the Orgone Amplifier circuit has the option to control frequency, so the user can select from a range of frequencies to tune feedback. This is particularly useful for users that encounter many situations, frequencies and use cases, such as commuting to urban or industrial environments.

### **Power to Weight Ratio**

A large advantage of the orgone amplifier circuit is the power to weight ratio. Organite cloud busters are very large, heavy and often cannot be transported economically. The orgone amplifier circuit has an impressive range for the size and weight. The OA circuit is so portable it can be trimmed down to just a few ounces, allowing the user to bring the device many places where a cloudbuster would not be feasible. For example, backpacking is an activity that needs every ounce to be shaved, as the extra weight can be felt in each step. With a lightweight device such as the OA-100, backpacking with a cloudbuster is now possible.

### **Operator Environmental Feedback**

Organite has the ability to tune feedback from the environment, and the OA circuit builds on this ability. By including the antenna and inputting received EM signals into the positive feedback oscillator circuit, the Orgone Amplifier is able to respond to incoming energy and adjust orgone output



based on environmental needs. By using communication grade antennas, impedance matching circuitry and optimum power harvesting techniques, the device is able to capture a wide range of frequencies in the heavily trafficked bands used by today's consumer devices.

### **Ability to Scale**

Due to the accessibility of the components, it is much easier and cheaper to scale this circuit compared to organite. At time of writing the cost of a medium size cloudbuster is well over \$500. An OA circuit can be created with salvaged electronic components, and if proper parts are purchased, is achievable well under \$100. The power available to an OA circuit is a 5x increase per dollar over an organite cloudbuster. The ability to scale this circuit will dramatically increase the total area exposed to orgone energy. We claim is that this circuit, when scaled, will be able to emit orgone with the intensity and range unlike any orgone device created previously, and unattainable to current organite technology. We expect future devices to have enough power to cover hundreds of square miles.

### **Improvements & Future Work**

The Orgone Amplifier circuit will have many different variations, and below we list some improvements and added features that are possible with a little ingenuity.

### **Extended Frequency Response**

By selecting antennas of different type, the circuit can receive feedback from a greater range of frequencies. Ultra low frequencies such as the Schumann resonances need ultra long antennas, while 5G antennas are short and often directional. Including an array of different antennas creates a multi-band receiver, which allows the user to tune into a specific bands or multiple frequencies if desired.

### **Directional Antennas**

By adding directional antennas the user is able to capture greater signal power coming from directed sources, such as cell phone towers in far away locations. Antennas of this nature include dish and patch antennas, which need to be oriented towards the source of EM radiation. This style of antenna works well if the location of the EM source is known. Using a directional antenna is beneficial for zeroing in on a source of radiation, drawing the strongest feedback from that source. Omnidirectional antennas are circular or spiral in shape, and allow the user to pick up well on EM radiation where the source is unknown or moving, as these antennas can be oriented in any direction with adequate gain.

### **Solar Power**

Current models use alkaline batteries, and although the batteries last a sufficiently long time, they are designed to be replaced once exhausted of the energy. Future models will have rechargeable batteries and the addition of a solar panel to power the device from renewable sources.

## **Greater Input Voltages**

With the availability of greater input voltages, the Orgone Amplifier circuit can apply greater magnitude pulses to the crystal. With a greater magnitude pulse, there must be a larger cross section of quartz material to handle the higher voltages. With greater power entering the crystal, a larger orgone intensity is generated, and therefore range increases according to the inverse square law as described in part 1 of the article series.

## **Increased Control**

The Orgone Amplifier has an option the ability to select frequencies and intensities. The device is an analog circuit, therefore a theoretical continuous range of frequencies and intensities are available to the user. Like an analog radio, the operator must tune to the desired setting to produce the intended effect. Some users prefer very fine control over the intended frequency, and to achieve this, multiple frequency dials are used with circuits specified with this feature. Each frequency dial is selected with cascading values, and like a caliper, one dial is used for coarse control while the next is used for one order of magnitude finer control. Finer control allows the operator to adjust input ratios of antennas, tuning into the desired band with less than 1% error.

## **Grounding**

The earth is somewhat conductive and acts as a large body of charge. Many electronics use this property for device safety and for sensitive circuits. The Orgone Amplifier will benefit from grounding, and it is possible to attach a ground wire to the gold plated antenna connectors so the OA can reference the earth ground. When grounded, the OA circuit has increased sensitivity to EM signals, and is more effective at detecting faint feedback signals. Grounding the circuit also allows for feedback from earth's natural electromagnetic oscillations.

## **Scalar Orgone Emission**

The OA design described in this paper is a scalar orgone device when the crystal is terminated in the XY plane. By using the XY plane the emitter vibrates along the plane of stimulation, similar to the scalar field. It is possible to create more complex vibrations within the crystal lattice by utilizing other cuts in tandem with the standard XY cut. A more detailed description of the scalar field and the Orgone equivalent will be offered in part 3 of the Orgone Amplifier article series.

## **Tensor Orgone Emission**

It is possible to turn the Orgone Amplifier circuit into a Tensor Orgone emitter by terminating the crystal emitter with both the XY plane and also the AT plane. A separate dial is needed to adjust the ratio between scalar orgone emission and tensor orgone emission. A more detailed description of Tensor Orgone will be offered in part 3 of the Orgone Amplifier article series.

## **Multi – Phase Crystal Stimulation**

It is possible to stimulate the crystal in more than one direction within the same plane, with each crystal face accepting one phase in a three phase system. With this configuration, the crystal is able to

accept 1.73x the power available to a single phase when in a 3 phase delta configuration, 3x the power in a 3 phase star configuration, and 6x the power in a 6 phase star configuration.

### **Vortex Generator**

Many have been to locations where natural energy vortexes form, and these locations are areas where orgone energy spontaneously forms a rotating field. This is a naturally occurring rotating tensor orgone field, and can be replicated with an orgone amplifier running a multi-phase tensor emitter. The multiple phases cause the electric field within the emitter to rotate, causing the generated orgone energy to spin, creating the rotating orgone energy field.

### **Radionics Input**

It is possible to modulate the orgone energy field according to an input signal from an external device. It is possible to include a feature in the Orgone Amplifier circuit to modulate radionics rates over the orgone spectrum, with the combined properties of both the radionic input and orgone exposure.

### **Audio Input**

With the addition of an external input signal, the Orgone Amplifier circuit also has the ability to re-broadcast audio input over the orgone spectrum, similar to an AM radio. A multitude of input devices can be engineered into the OA circuit in this way, including microphones, instruments, sound healing devices, light sensitivity and ultrasonic sensors. Audio output is in active research.

### **Aura /Brainwave/Bio-metric sensing**

Both brain waves and the aura express themselves as a component of Body's natural electrical field. Extremely sensitive electronic circuitry can be designed to detect changes in Aura, brain wave and bio-metric activity. It is possible to input these natural signals into the OA circuit once detected and conditioned to attainable voltage levels.

## **Conclusion**

In this article we have explored the oscillatory motions of the circuit and described the operation in great detail. By understanding the implementation of the Orgone Amplifier circuit, we can see that there are many advantages. The circuit is very simple and very robust. The design is completely analog and responds directly to the natural laws of the universe. There is no information lost by introduction of any signal processing or digitizing of any signal. There is no micro-controller or proprietary software that operates this device. The circuit can be built with components that are found around the house in old electronics. The circuit is scalable and can work in a very wide range of frequencies, temperatures, altitudes and pressures. The circuit oscillations are spontaneous and the device has an affinity for oscillations. Finally, the device is knowable. It is understandable. The mechanics are so commonplace the ideas cannot be patented and hidden. The device relies on only a handful of components that are so common that the sale and use cannot be regulated or controlled, or it would have broad implications for the entire electronics sector. The more digestible the device is, the more likely the ideas will proliferate, the more likely we will see different applications, more evidence, and improvements. It is for this reason a detailed description of the operating theory and construction of the device has been made open

source and entered into public domain under the GPL v3 license. The next article in this series will explore orgone and secondary effects in more detail, leading to a unified orgone theory that explains the mechanism behind many observed phenomena.

The OA project encourages readers to build Orgone Amplifier circuits for themselves, their family and friends at their own discretion, however “Orgone Amplifier” is a trademarked brand held by Orgone Amplifiers LLC. Orgone Amplifiers LLC reserves the right to enforce branding rights on entities selling products branded as an “Orgone Amplifier” on the open market. Individuals or entities building on the technology offered in this article are allowed to use any other branding they wish. Part of being an open-source project is adhering to the rules of open source development. This means, any product or design that is achieved using the ideas presented in this article must also release the source material for others to build. We all stand on the shoulders of giants, and it is the responsibility of every reader to allow future generations to benefit from the same.

## References

- 1: Nivaldo J. Tro, Introductory Chemistry,
- 2: Demetrius T. Paris and F. Kenneth Hurd, Basic Electromagnetic Theory, 1969
- 3: , The Antenna Theory Website, , <https://www.antenna-theory.com/>
- 4: , Fouier Series Simulation of a Square wave, , <https://www.youtube.com/watch?v=k8FXF1KjzY0>
- 5: , Antenna(Radio) Wikipedia, , [https://en.wikipedia.org/wiki/Antenna\\_\(radio\)](https://en.wikipedia.org/wiki/Antenna_(radio))
- 6: Mohamed M. Mansour, Haruichi Kanaya, Impedance Matching Antenna-Integrated High-Efficiency Energy Harvesting Circuit, 2017
- 7: Joseph R. Eoff, Voltage multipliers - Part 5 Tying it all together, 2019,
- 8: Zohaib Hameed,Kambiz Moez, Design of impedance matching circuits for RF energy harvesting systems, 2016
- 9: Zohaib Hameed,Kambiz Moez, Design of impedance matching circuits for RF energy harvesting systems, 2016
- 10: , Quartz Crystal Cuts: AT, BT, SC, CT, , [https://www.electronics-notes.com/articles/electronic\\_components/quartz-crystal-xtal/crystal-resonator-cuts-at-bt-sc-ct.php](https://www.electronics-notes.com/articles/electronic_components/quartz-crystal-xtal/crystal-resonator-cuts-at-bt-sc-ct.php)
- 11: All About Circuits, Kirchoff's Voltage Law (KVL), , <https://www.allaboutcircuits.com/textbook/direct-current/chpt-6/kirchhoffs-voltage-law-kvl/#:~:text=REVIEW%3A,a%20loop%20must%20equal%20zero>

Thank you for reading,  
-Dr. Jaidon Chase

Facebook: @OrgoneAmplifiers

Instagram: @orgoneamplifiers

Email: [orgone.amplifier@gmail.com](mailto:orgone.amplifier@gmail.com)

*Jaidon Chase received his doctorate at the College of Applied New Wellness out of Nederland, Colorado for his invention and defense of the Orgone Amplifier circuit. Jaidon has been studying semiconductors, electronics and electrical engineering for 15 years and has designed solar arrays, power supplies, stereo amplifiers, electronic synthesizers, communications equipment and computer simulations. Jaidon first came in contact with orgone and organite at Arise Music Festival in 2019, and researched these theories during the pandemic. The first Orgone Amplifier was built in 2022.*



-----BEGIN PGP PUBLIC KEY BLOCK-----

```
mDMEYtJjoRYJKwYBBAHaRw8BAQdAxtLlShU7F1mrmc+Z0bxJQj1rgkIpzF5yBZHC
aYJP2oq0LURyLiBKYWlkb24gQ2hhc2UgPG9yZ29uZS5hbXBsaWZpZXJAZ21haWwu
Y29tPoiZBBMWCgBBFiEEjB1pIcYhOUbrX5ZlXA3cWS/Fnj0FamLSY6ECGwMFCQPE
NV8FCwkIBwICigIGFQoJCAscBBYCAwECHgcCF4AACgkQXA3cWS/Fnj2gYAD+N0bz
3ECb0Gu5F+q7gD16VqTuhWkt1UOLtuhi0cV1cEgBAPaju75JUazpKIkyd9AW3p4W
2GLmSCtNl5QgomjUnicCuDgEYtJjoRIKKwYBBAGXVQEFAQEhQFlZNVzV9bF2YI9W
omt+BCsO/WzPwhXdYKRguu+UpbhrAwEIB4h+BBgWCgAmFiEEjB1pIcYhOUbrX5Zl
XA3cWS/Fnj0FamLSY6ECGwwFCQPENV8ACgkQXA3cWS/Fnj0wuQEAlMxVchwVo9Cn
jbQgRLncDoMmdnXSU4nz4lP3mFX8BEA/31rtIKGWGLY0VHlcjqr3iTzucLBCRNj
O1oYkEYblZ4L
```

=+ERw

-----END PGP PUBLIC KEY BLOCK-----